

Stressed Skin Wood Surface Structures

Potential Applications in Architecture

AnnaLisa Meyboom
University of British Columbia

David Correa
University of Waterloo

Oliver David Krieg
LWPAC + Intelligent City



1

ABSTRACT

Innovation in parametric design and robotic fabrication is in reciprocal relationship with the investigation of new structural types that facilitate the technology. The stressed skin structure has historically been used to create lightweight curved structures, mainly in engineering applications such as naval vessels, aircraft and space shuttles. Stressed skin structures were first referred to by Fairbairn in 1849. In England, the first use of the structure was in the Mosquito night bomber of World War II. In the USA stressed skin structures were used at the same time, where the Wright Patterson Air Force Base designed and fabricated the Vultee BT-15 fuselage using fiberglass-reinforced polyester as the face material and both glass-fabric honeycomb and balsa wood core. With the renewed interest in wood as a structural building material due to its sustainable characteristics, new potentials for the use of stressed skin structures made from wood on building scales are emerging. The authors present a material informed system that is characterized by its adaptability to free form curvature on exterior surfaces. A stressed skin system can employ thinner materials that can be bent in their elastic bending range and then fixed into place, leading to the ability to be architecturally malleable, structurally highly efficient as well as easily buildable. The interstitial space can also be used for services. Advanced digital fabrication and robotic manufacturing methods further enhance this capability by enabling precisely fabricated tolerances and embedded assembly instructions; these are essential to fabricate complex, multi-component forms. Through a prototypical installation, the authors demonstrate and discuss the technology of the stressed skin structure in wood considering current digital design and fabrication technologies.

- 1 The Wander Wood Pavilion, a double-curved stressed skin structure made from single-curved wooden elements.

INTRODUCTION

Innovation in parametric design and robotic fabrication can unlock new structural types to facilitate these designs. The stressed skin structure (Figure 2) has played a key role in enabling the development of highly efficient light weight vessels with free-form geometries. This structural type consists of two thin surfaces (such as metal plate or plywood) with an interstitial material, forming the web, which connects the plates. In the context of aircraft or naval vessel's complex geometry, this system requires for each web to be unique and for its skin to be precisely formed to match the web. While the system provides great structural and material efficiencies, the high cost of the custom fabrication process has limited the application of these types of systems for building construction – where mass standardization or expensive customization is currently the norm. That is, with the notable example of the structurally insulated panel (SIP) which is considered a stressed skin structure but is primarily designed as a flat product. This type of structure has had limited application in buildings, aside from the structurally insulated panel, but has great potential not only for allowing freedom in forms but also for integrating design with building services.

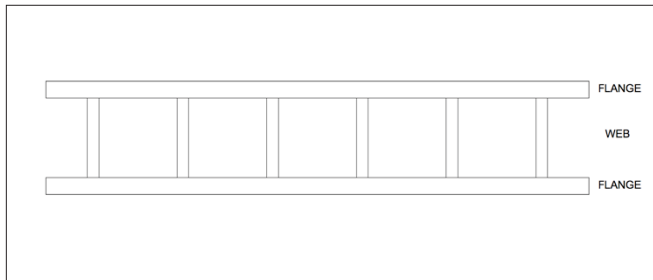

2

2 Sectional drawing of a stressed skin structure arrangement.

Concerns about sustainability are leading to a renewed interest in wood construction in many countries and a new interest in innovation in wood products. Plywood, Laminated Veneer Lumber (LVL), Glulam, and Cross Laminated Timber (CLT) are engineered wood products that have been developed to increase homogeneity, therefore reliability and strength, and create dimensional stability in otherwise anisotropic materials. Each product and each subcategory of it, while exhibiting generally enough characteristics to be used in very different types of buildings, are made, and subsequently optimized, for a particular structural purpose. Each has its grain oriented for a specific structural behavior or a specific loading condition. However, academic research has been questioning the approach toward wood design and has engaged in new ways of thinking about how we build in wood in recent

years. Recent work into structural variability of timber components (Self, 2017), integrated Joinery (Robeller, 2017; Krieg, 2013), or environmentally active shape-changing wood systems (Reichert et al, 2015) present a new conceptual approach that is decidedly specific to the performance characteristics of wood in each specific application. These developments have only been possible through advances in design approach, computational methods and advances in engineering modelling of material configurations (Correa, Krieg, and Meyboom 2019).

Taking this idea further, with advanced fabrication technology it is possible to see that in the future specific engineered wood products will be custom fabricated for individual projects. For instance, precisely curved custom laminated wood elements with specific grain were used in Shigeru Ban's curved elements for the Haesley Nine Bridges Golf Course Club House (2009): the structure's members are individually fabricated from custom laminated veneers, manufactured by Blumer Lehman. Each component was structurally designed for specific architectural applications rather than a generic structural loading condition. Research into this type of custom engineered wood product in the form of a double curved CLT shell structure was carried out as well with specific applications to custom individual buildings in mind (Cheng et al. 2015). The dedicated development of adaptive structural and fabrication methods implemented for a specific design are blurring the line between "engineered wood product" and the custom structure. Generally, the ability to customize wood's performance for its structural requirements through fabrication techniques and material engineering, regardless of the scale or its typology, is one of the reasons for its large potential in the 21st century.

With the renewed interest in wood as a structural building material due to its sustainable characteristics, there are new potentials for use of stressed skin structures for buildings. One of the aspects of the system which may be of particular interest is its ability to adapt to free form curvature on the exterior surfaces. A stressed skin system can use thinner materials that can be bent in their elastic bending range and then fixed into place, leading to the ability to be architecturally malleable, structurally highly efficient as well as easily buildable. Advanced digital fabrication and robotic manufacturing methods further enhance this capability by enabling precise fabrication tolerances and embedded assembly instructions, these are essential to the ability to fabricate complex, multi-component forms.

In addition to facilitating a highly expressive structure, the stressed skin also provides an interstitial space – similar

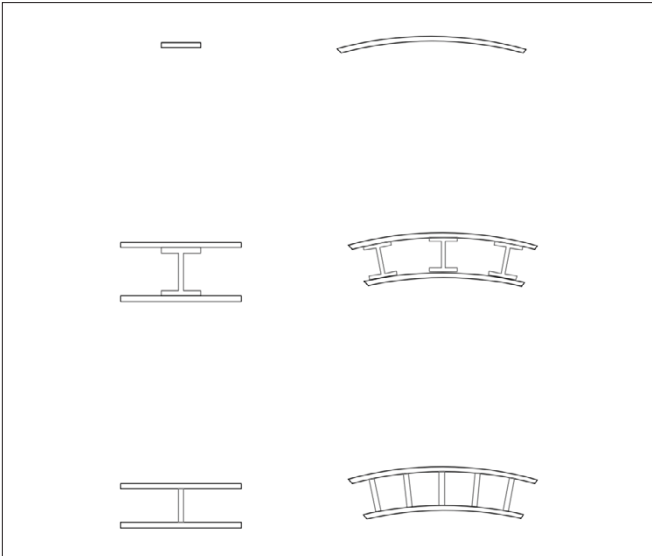

3

3 Top: A monocoque shell consists out of a single layer of material. Middle: A frame structure consists of main internal elements and a connecting skin. Bottom: A semi-monocoque or stressed skin structure actively uses the skin as part of the structure and integrally connects to the web.

to the space between joists - that can be used to integrate services such as sprinklers, wiring and pipes or lighting within it.

Stressed skins can also be used as a double skin approach for buildings. This is a well-known sustainable design approach that applies to roofs as well as walls (Zingre, Yang, and Wan 2017). The approach uses the top roof to shade the bottom roof and ventilation is utilized between the roof levels to add to convective heat transfer methods.

BACKGROUND

Definition of stressed skin structures

The stressed skin structure can come in various forms – a stressed skin (or sandwich) beam, plate or shell. They can also have a range of cores – from insulation (as in the structural panel) to a honeycomb core, a web core (as in the installation shown) and the truss core (which is the form of a truss). From a structural point of view, the essential function is that the skin is actively used as part of the structure and integrally connected to that which makes up the core so that the beam action of the entire depth of the panel can be engaged. The skins on either side of the panel act as the flanges and take the bending stresses while the internal structure of the panel, regardless of its type, transfers the shear forces. (Figure 4)

Stressed skin structures have mainly been used in engineering applications of moving objects such as planes, spaceships and cars, due to the requirement for

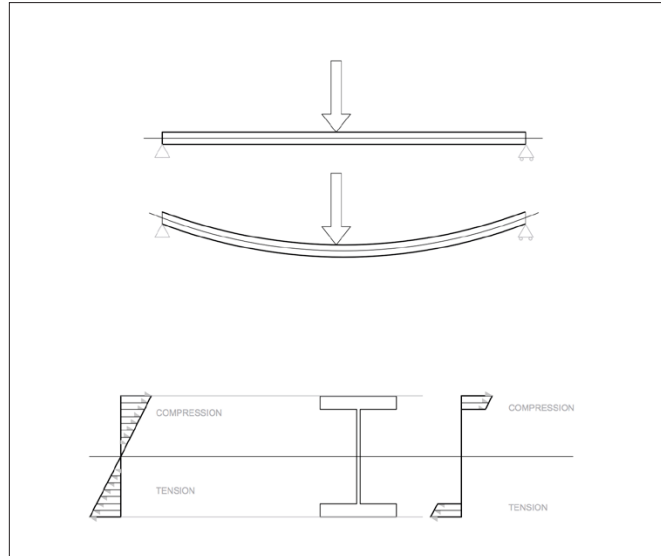

4

4 The function of a stressed skin structure in bending. Top: View of a typical bending force on a truss or roof in section. Bottom: The forces are distributed in a stressed skin similar to those in I-beams. Bending is divided into compression and tension along the skin.

lightweight, strong and aerodynamic shapes which require curves – all of which the stressed skin does well.

They are also referred to as sandwich construction and double hull construction (with some distinctions) were first referred to by Fairbairn in 1849 (Fairbairn 1849). In England, the first use of the structure was in the Mosquito night bomber of World War II (J. R. Vinson, n.d., 202). In the USA stressed skin structures were used at the same time, where Wright Patterson Air Force Base designed and fabricated the Vultee BT-15 fuselage using fiberglass-reinforced polyester as the face material and using both glass-fabric honeycomb and balsa wood core (J. R. Vinson, n.d., 202). The first paper regarding this type of structure was published in 1944 by Marguerre dealing only with in-plane bending stresses (Marguerre 1944). Further development with regard to bending, buckling and boundary conditions followed quickly in subsequent years (Hoff, 1948) (Libove and Batdorf, 1948) (Flügge, 1949, 1952). In the 1960s, more sophisticated methods were developed by Plantema (Plantema 1966) and HG Allen (Allen 1969) which remained the main resources for engineers until the mid-1990s. By 1966 there were over 250 publications on sandwich structures (J. Vinson and Shore 1965). Sandwich shells - wherein the shell structure is a sandwich structure - is a field in which NASA has done considerable research.

Stressed skin structures are increasingly used in aircraft, satellites and spaceships. The Boeing 707 utilized a sandwich structure for 8% of its fuselage, whereas the 757/767 utilized a sandwich structure for 46% of its surface. The



5

5 Robotic fabrication and modular assembly process. Each piece was cut in a 5-axis CNC process using an extended 7-axis robotic setup. Afterwards, the elements were assembled into 5 separate modules small enough to be transported across campus. The assembly took place in the workshop under controlled conditions. The modules were then assembled on site into the final demonstrator.

747's fuselage is primarily honeycomb sandwich, and the floors, side-panels, overhead bins, and ceiling are also of sandwich construction. A major portion of the American Space Shuttles are honeycomb sandwich panels and almost all satellites use sandwich construction (Bitzer 1997; J. R. Vinson, n.d.). Further, this type of structure is in widespread use in naval vessels and high-speed rail cars. Sailboats, racing craft, and auto race cars also all use sandwich construction and it can also be used for snow skis, water skis, kayaks, and canoes.

There has historically been some research in stressed skin panels in wood – particularly structurally insulated panels which are a form of stressed skin. Research on stressed skin panels was performed initially by the U.S. Forest Product Laboratory in 1935 and in 1960, the Douglas-Fir Plywood Association (now American Plywood Association (APA)) started a research project to improve the use of stressed skin panels and to also design standards (Drawsky 1960). In Germany, design research was carried out at FPL by Möhler et al (Möhler, Abdel-Sayed, and Ehlbeck 1963). The APA published its first Plywood Design Specification - Supplement 3 for SSP design in 1970 which is currently in use in the U.S. with some amendments. Further research has been carried out and Europe has their code the EN 1995-1-1 standard which includes a stressed skin panel design procedure (glued thin-flanged beams). Luengo and al. have more recently completed a study using CLT stressed skin panels which offers a promising new approach for larger spans (Luengo et al. 2017).

RESULTS AND DISCUSSION: DEMONSTRATOR

The Wander Wood Pavilion (Figure 5-9) relies on a stressed skin structural approach in order to provide complex free form geometry, thorough the elastic bending behavior of plywood, while maintaining structural stability as an extremely light-weight structure. These three characteristics are critical for the success of the project. Much like a plane, the definition of the shape via a thin skin reduces weight and material use, while the coupling of skin and webs allow for the transfer of load across the entire structure. For the purpose of a temporary architectural pavilion these two characteristics are essential to reducing material and manufacturing costs while it simultaneously facilitates assembly and installation requirements on site. The demonstration project is composed of 100 overlapping skin elements made from $\frac{1}{4}$ " plywood and 50 ribs fabricated with $\frac{3}{4}$ " plywood. Dimensional accuracy of each component as well as embedded assembly information, in the form of pre-drilled fastening guides, are implemented through the robotic fabrication process.

Making use of the 6 degrees of freedom of the manipulator, plus the extended reach of the linear track (7 axis), allows for extended machining into each sheet of stock material. The robustness of this system allows for local differentiation in geometric, structural and functional performance. For instance, the system was locally adapted to provide a much stiffer sitting area in one end while having a lighter, light modulating screen, on the opposite end. Geometrically, the system also seamlessly integrates double curvature



6

6 View of the installation from east. From this perspective the bench is gradually extruding out of the structure to form an interior seating area and providing a space for students to rest.



7

7 Detail of the connections between elements. The stressed skin is formed by vertical plywood strips that connect to each other with flaps, making it possible to bend in a direction other than the strips themselves.



8

8 View of the installation from west. What is considered the outside of the structure mainly forms a concave surface that invites visitors to walk around and be drawn into the other side. From this side the gradient of opening is more pronounced and shows the versatility of the aesthetic expression.

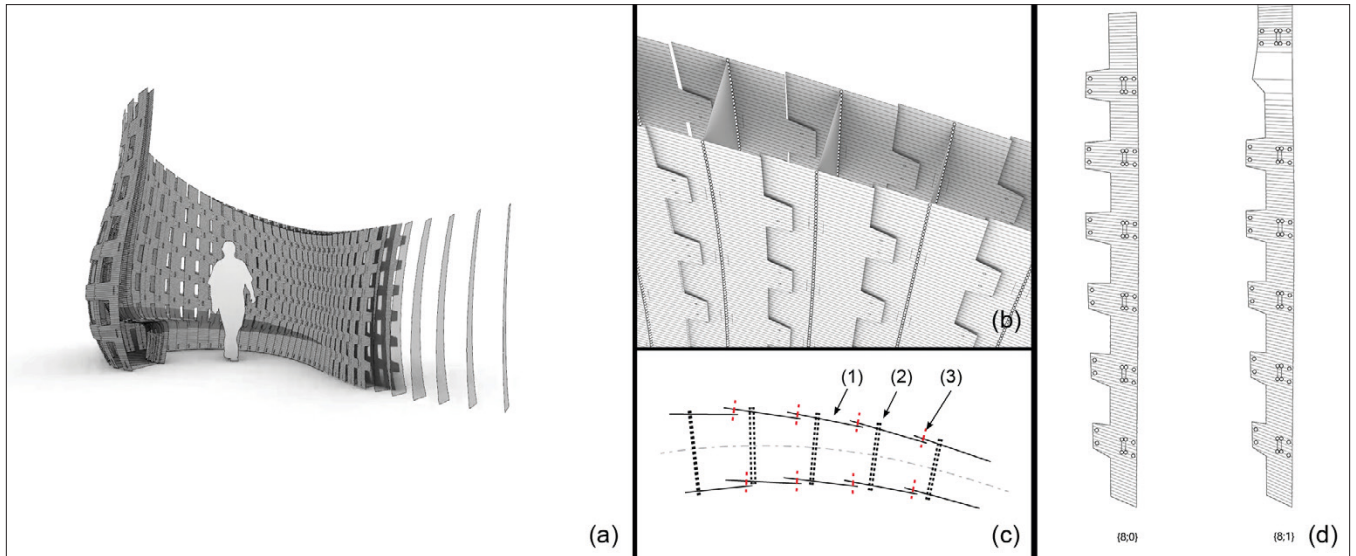

9 Computational Design tools indicating global geometry (a), stressed-skin structural system detail from above (b) and system components connection and assembly (c & d). Including the flange (1), web (2) and the rivets positions (3). In a parametric model the individual elements are generated based on their single curvature. They are then unrolled and generated as flat elements that can be manufactured using CNC techniques.

changes across the length of the demonstrator from synclastic (Fig.8 - taller end) to anticlastic (Fig. 8 - near the lower section of the design).

The modularity of a stress skin system, where each section of webs has certain structural autonomy, allows for the overall structure to be assembled in sections prior to installation on site. This is an assembly principle widely used in naval and aeronautical architecture where the scale of the build is not suitable to the assembly line process – a similar challenge that is directly shared with building construction. Moreover, the interstitial “cavity” space resulting from this optimized approach combined with its assembly modularity provides unique technical opportunities to integrate additional mechanical and electrical services within the system itself. Aeronautics has made well use of this advantage to enable fuselage systems that can be easily customized to specific uses without compromising access for mechanical maintenance. Therefore, paying homage to this aeronautical legacy and with a keen interest in the fastening advantages of rivets over nuts and bolts, the pavilion’s skin is fastened using over 2200 aluminum rivets – similar to those used in airplane fuselage. Each rivet location is designed through a form-finding method during the computational design process, to ensure final form, while its location is pre-determined and pre-drilled into all the plywood skin elements during the robotic fabrication process (figure 5&9). During the assembly, these pre-drilled orifices self-align the structure over multiple components and therefore guarantee the overall geometry accuracy of the intended design.

Unlike a conventional approach to form definition, where a subtractive milling process (like CNC) is applied to large solid component(s) and shear mass or a secondary structure is used for structure stability, the presented method builds on the optimization lessons borrowed from aeronautics to integrate form definition and structural intelligence into one single materialization process. Rather than having discrete methodologies for form definition, structure, mechanics and assembly – a separation that is typically reflected in disciplinary expertise (designer, engineer, builder/fabricator), the Wander Wood Pavilion applies a multi-level approach to integration, where form and structure, performance and assembly - and ultimately design and materialization - emerge as a direct dialog. This concept of integrative design requires a set of fundamental shifts in disciplinary thinking, practice and production economy. This project is a humble materialization of this methodology put into practice.

CONCLUSION

The demonstration project testifies to the stressed skin structure’s ability to create double curved structures that are structurally robust and materially efficient. Demonstrated by its extensive use in aeronautics, the potential of this structural and material informed approach using wood lies in its ability to be implemented at multiple scales while addressing complex geometries and divergent performance requirements, ranging from a large enclosure to a wall system. The stressed skin typology, while demonstrated here as a double curved structure,

can be used as a flat plate, folded plate, or single curved structure. The advantage of using a folded plate or curved structure is that some structural efficiencies can be gained from the geometry of the global structure as well as the stressed skin structure itself. In a context of integrated design-to-fabrication, this scaled-up capacity can create highly informed building-scale structures in wood that are structurally optimized for both material use and building integration. Its modularity, as well as the potential to use the interstitial space of the double skin structures, can facilitate integration of additional mechanical or electrical services - a level of integration that has been long awaited in building construction. Advanced computational design and fabrication processes are instrumental to take advantage of these more challenging global structural shapes, which is why the discussion is relevant at this time of advancing parametric and fabrication sophistication.

ACKNOWLEDGEMENTS

The workshop presented in this paper was organized and supported by the Centre for Advanced Wood Processing, as well as the School of Architecture and Landscape Architecture at the University of British Columbia. Funding was provided by the Forestry Innovation Investment, Perkins+Will Vancouver, Perkins+Will Building Technology Lab, and the UBC SEEDS Sustainability Program.

REFERENCES

Allen, HG. 1969. *Analysis and Design of Structural Sandwich Panels*. Oxford: Pergamon Press.

Benson, Chandler. n.d. Wood Deck Structure. US3345792A. <https://patents.google.com/patent/US3345792A/en>.

Bitzer, TN. 1997. *Honeycomb Technology: Materials, Design, Manufacturing, Applications and Testing*. Springer Science & Business Media.

Cheng, Alexandra, Thomas Gaudin, AnnaLisa Meyboom, Oliver Neumann, and Thomas Tannert. 2015. "Large Scale Wood Surface Structures." In 3rd Annual International Conference on Architecture and Civil Engineering. Singapore.

Correa, David, Oliver David Krieg, and AnnaLisa Meyboom. 2019. "Beyond Form Definition: Material Informed Digital Fabrication in Timber Construction." In *Digital Wood Design*, 61–92. Springer.

Coz Díaz, J. J. del, P. J. García Nieto, F. P. Álvarez Rabanal, and C. Betegón Biempica. 2008. "Finite Element Analysis of Thin-Walled Composite Two-Span Wood-Based Loadbearing Stressed Skin Roof

Panels and Experimental Validation." *Thin-Walled Structures* 46 (3): 276–89. <https://doi.org/10.1016/j.tws.2007.07.020>.

Drawsky, RH. 1960. "Stressed-Skin Panel Tests." 82. Tacoma, Washington, USA: Douglas Fir Plywood Association.

Fairbairn, William. 1849. *An Account of the Construction of the Britannia and Conway Tubular Bridges*. London. <http://hdl.handle.net/2027/mdp.39015095176528>.

Gerber, C. D. 2007. "Wood Stressed-Skin Panels : An Investigation into Their Behaviour, Load Distribution and Composite Properties." Thesis. <https://opus.lib.uts.edu.au/handle/10453/37520>.

Ivan Bertram Juriss Roger Douglas Hay Andrew Culross Goodfellow Thomas Townson Keith Eric Hay. n.d. *Structural Building Panels*. US4012882A, filed 1973 1973. <https://patents.google.com/patent/US4012882A/en>.

Luengo, Emilio, Eva Hermoso, Juan Carlos Cabrero, and Francisco Arriaga. 2017. "Bonding Strength Test Method Assessment for Cross-Laminated Timber Derived Stressed-Skin Panels (CLT SSP)." *Materials and Structures* 50 (4). <https://doi.org/10.1617/s11527-017-1069-8>.

Marguerre, K. 1944. "The Optimum Buckling Load of a Flexibly Supported Plate Composed of Two Sheets Joined by a Light Weight Filler When under Longitudinal Compression, ." *Deutsche Vierteljahrsschrift Fur Literaturwissenschaft Und Giests Geschichte (DVL) ZWB UM1360/2* (October).

Michael Davies, J. 2006. "Developments in Stressed Skin Design." *Thin-Walled Structures, Tribute Edition to Rolf Baehre*, 44 (12): 1250–60. <https://doi.org/10.1016/j.tws.2007.01.002>.

Möhler, K, G Abdel-Sayed, and J Ehlbeck. 1963. "Zur Berechnung Doppelschaliger, Geleimter Tafelelemente." *Holz Als Roh-Und Werkstoff* 21 (8): 328–333.

Nicholas, Paul, David Stasiuk, Esben Nørgaard, Christopher Hutchinson, and Mette Ramsgaard Thomsen. 2016. "An Integrated Modelling and Toolpathing Approach for a Frameless Stressed Skin Structure, Fabricated Using Robotic Incremental Sheet Forming." In *Robotic Fabrication in Architecture, Art and Design 2016*, edited by Dagmar Reinhardt, Rob Saunders, and Jane Burry, 62–77. Cham: Springer International Publishing. https://doi.org/10.1007/978-3-319-26378-6_5.

Plantema, FJ. 1966. *Sandwich Construction: The Bending and Buckling of Sandwich Beams, Plates and Shells*. New York: John Wiley & Sons.

"Stressed Skin Panels FP 2.3.1." 1987. Edmonton, Canada: Alberta Research Council Industrial Technologies Department, Forest

Products Program.

Vinson, Jack R. 2001. "Sandwich Structures." *Applied Mechanics Reviews* 54 (3): 201–14. <https://doi.org/10.1115/1.3097295>.

Vinson, JR, and S Shore. 1965. "Bibliography on Methods of Structural Optimization for Flat Sandwich Panels." NAEC-ASC-1082. Naval Air Engineering Center.

Zingre, Kishor T, En-Hua Yang, and Man Pun Wan. 2017. "Dynamic Thermal Performance of Inclined Double-Skin Roof: Modeling and Experimental Investigation." *Energy* 133: 900–912.

projects are characterized by an integrative approach towards engineering, material science, sustainability, building physics, and manufacturing.

IMAGE CREDITS

Figure 5 by Elton Gjata. All other drawings and images are by the authors.

BIOGRAPHIES

AnnaLisa Meyboom is an Associate Professor at the University of British Columbia in the School of Architecture and Landscape Architecture (SALA). Her research interrogates future applications of technology in the design of our built environment. She emphasizes the need to integrate the highly technical, the beautiful and the environmental simultaneously and seamlessly into built form. She holds a degree in engineering from University of Waterloo and a Masters of Architecture from the University of British Columbia. She designs and writes about future infrastructures and the use of advanced digital tools in the design and fabrication of architectural form.

David Correa is an Assistant Professor at the University of Waterloo and a Design Partner at ILLab - an experimental design collaboration based in Shanghai. His research looks at biological structures and processes as a source of insight for the development of high-performance fabrication processes and materials. The research leverages digital fabrication tools (robotic manipulators, 3D printers and CNC milling) to engage complex material behaviour at different scales. Inter-disciplinary research initiatives include weather responsive shape active facade components (with Plant Biomechanics group, University of Freiburg), large scale bio-based 4D printing and robotic fabrication of timber structures (CAWP+SALA, UBC).

Oliver David Krieg is an expert in computational design and digital fabrication in architecture. As Director of Technology at LWPAC in Vancouver, Canada, and doctoral candidate at the Institute for Computational Design and Construction at the University of Stuttgart, Germany, his work aims to enable reciprocities between design, technology and materiality in order to re-conceptualize how architecture can be designed, fabricated, and constructed. His