

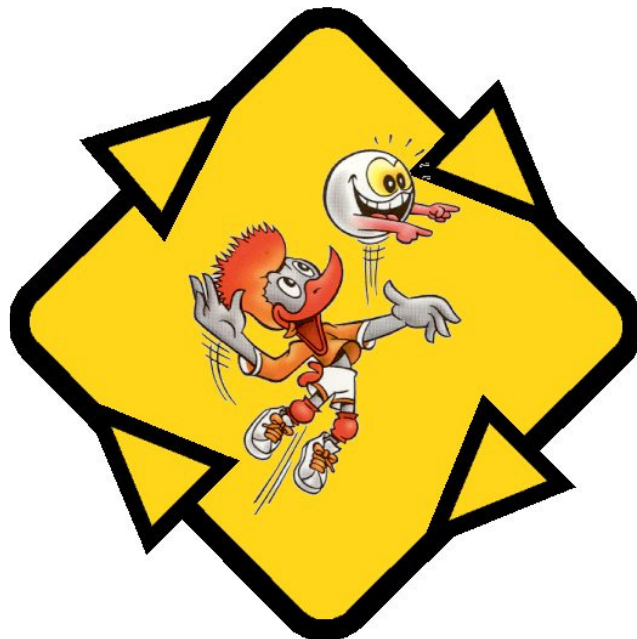

Circulation- and minivolleyball (CMV)

Rules of the game



2007-2010



INTRODUCTION

Circulation- and minivolleyball

By Wilco Nijland

Product manager Youth Volleyball

Background

- Physical education teacher (middle school)
- Graduated in Sports management
- Head Coach different youth volleyball teams

Dutch Volleyball Federation

Huis van de Sport

P.O. Box 2659

3430 GB Nieuwegein

The Netherlands

T. (+31)30 - 7513628

M. (+31)6 - 13895167

F. (+31)30 - 7513601

Introduction to the topic

In 2000 the NeVoBo introduced a new form of volleyball for 6-12 year olds. The old, static 4 against 4 game was transformed into a new, dynamic variation of volleyball; the circulation volleyball - mini volleyball (CMV).

CMV offers the children from 6 years and up an entire volleyball education in six steps. They start at Level 1, a throw-catch variant whereby the entire team has to rotate each time the ball has crossed the net. At each next level the children are taught a new volleyball technique, so when they reach Level 6 they have mastered all the volleyball techniques and are ready to play 6 against 6.

Circulation volleyball - mini volleyball is characterized by the many movements (after each ball that has crossed the net, all the members of the team have to rotate to the next position) and by a well thought-out setup of techniques (each level, 1 new technique). Also the accessibility and the possibility to differentiate contribute to the success of CMV. Both these aspects make CMV the method to learn how to play volleyball, at the club, the elementary school and even at high school!

Since the introduction of CMV the number of youth volleyball members (6-12 year olds) of the Dutch Volleyball Federation is growing from 5000 members in 2000 to 26.000 members in 2007! We are very satisfied by this huge success!

CIRCULATIONVOLLEYBALL - MINIVOLLEYBALL



EXPLANATION TO THE RULES

Courtdimensions levels 1 till 4

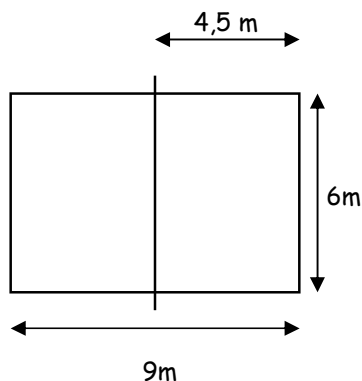

Courtdimensions levels 5 and 6

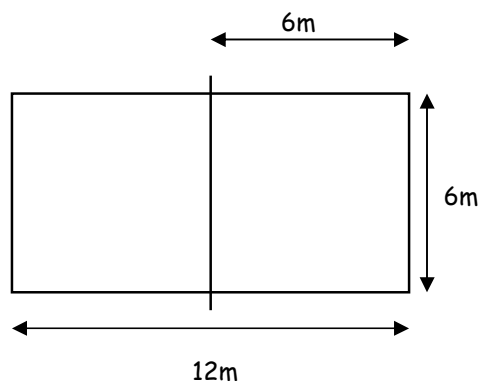

1. At every level the age is mentioned. This is an indication of the age where the player at a certain level should be able to play and we also assume that the player has gone through the previous levels. Is the player a starting volleyballplayer, than it is up to the coach to determine the starting level of the player. There is one important rule: a player is allowed to play in a level which is two levels under his age.
2. At all levels the game is played 4 against 4 . We advice that the whole team does not exceed six players.
3. How do the reserves get into play? At level 1, 2 and 3 the goal of the game is to clear the opponents court. At every level there is a more difficult term for players to come back into the court (for the rules please refer to each level). The players who start outside the court, are the first players to enter the court, when this term is met. At level 4, 5 and 6 it is compulsory that players re-enter the court at the serving-spot.
4. We advise the new lighter and a soft outside material minivolleyball, especially for the first three levels. The different brands may vary in colour, durability and the choice of the outside material. There are also different manufacturers who make balls which make the transfer to the C-youth (12-13 years old) easier. These balls are special because of their soft and flexible outside and because they are lighter than the normal (senior) volleyball.
5. The game is directed by one person. Next to very good knowledge of the level played, this person is there to make sure the games runs in good order. In this way he or she is also working as a pedagogue and can expect help from the people who accompany both teams.
6. In a situation where the rules do not provide a solution, it is up to the matchsupervisor to decide. The official rules of the NeVobo are applicable.
7. All previous rules are herewith invalid.

Circulationvolleyball - level 1



(throwing, catching, moving)

| | |
|---------------------------|---------------------------|
| AGE: | 6 - 7 YEARS OLD |
| NUMBER OF PLAYERS: | 4 PLAYERS PER TEAM |
| COURT: | 6 X 4½ METER |
| NET HEIGHT: | 2.00 METER |

GOAL

The players try to get the ball over the net on to the floor of the opponent.

START

The ball can be thrown into the court over the net from any spot in the court.

RULES

1. After a player throws the ball over the net, the whole team rotates one position clockwise.
2. The players are not allowed to walk with the ball.
3. When the distance up to the net is too big, the player can pass the ball to a team-member and then the ball is played over the net.
4. The ball may touch the net.
5. When a player drops the ball or, throws the ball out of court or, throws the ball into the net, or touches the ball before it goes out of play, this player has to leave the court and take his/her place next to the court.
6. When the ball is thrown on the floor by an opponent, the player closest to that ball has to leave the court.
7. If there are only two players left in the court, these players switch places every time the ball is thrown over the net into the opponent's court.
8. A player can re-enter the court when a team mate catches the ball.
9. The player that was out of court the longest; returns first and begins closest to the net.
10. When all opponents are removed from the court, the team left scores 1 point.

WHEN IS THE GAME DEAD?

The game is dead when the ball is not caught, which means:

- the ball is thrown out;
- a player dropped the ball;
- the ball was thrown into the net;
- the ball was thrown onto the floor in the opponent's court.

WHAT HAPPENS WHEN THE GAME IS DEAD?

The game is resumed immediately by the player who has the ball at that moment, thrown anywhere in the court.

SCORE

When the opponent's court is empty the team left gets 1 point. The game starts again with 4 against 4 players. Decide beforehand if a match is played to a certain score or a time limit is set.

Circulationvolleyball - level 1



(throwing, catching, moving)

The graphics show: formation and way of rotation after the ball has crossed the net when the court is filled with four, three or two players.

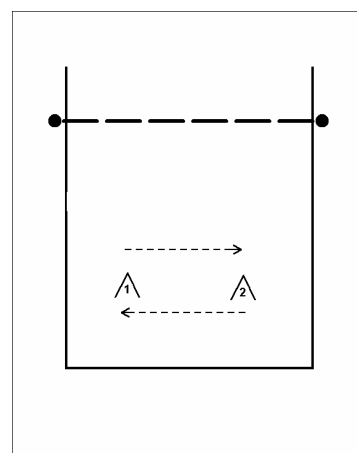
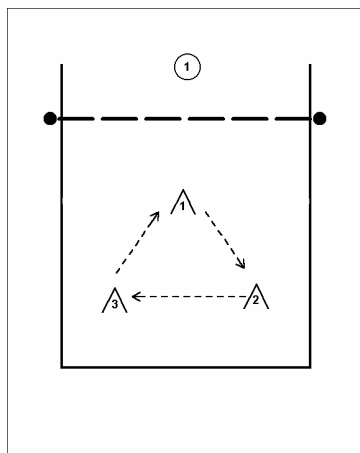
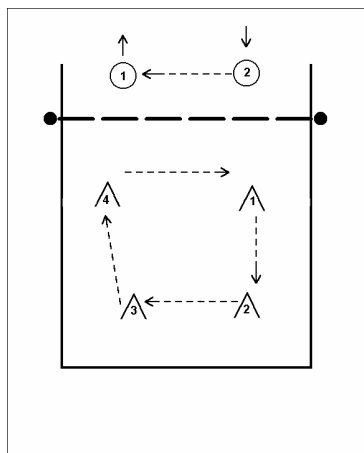

SPEED

Let the players throw the ball back right after they catch it, to get as much speed into the game and also as much speed into the moving of the players.

GOALS

1. Versatile, quick moving en reaction with constant recognition of the trajectory of the ball, through which the idea of movement of the own body and the ball through space is trained well.
2. The coach needs to stimulate the catching and throwing with two extended arms. This is an excellent method to teach the basic-movement of passing.
3. Throwing can also be done overhead by pushing out the ball, which is an excellent first phase for setting.
4. When the underarm-pass and overhead-pass get a steady shape, the player can also throw the ball with one hand above his/her head, this as a preparation to the tip-ball.



- Recognition of the trajectory of the ball
- Timing
- Throwing and catching in a way that is natural to volleyball. (see 2,3 en 4)
- Footwork (forwards, backwards and to the side)

Circulationvolleyball - level 2



(underhand serve)

| | |
|--------------------|--------------------|
| AGE: | 7 - 8 YEARS OLD |
| NUMBER OF PLAYERS: | 4 PLAYERS PER TEAM |
| COURT: | 6 X 4½ METER |
| NET HEIGHT: | 2.00 METER |

GOAL

The players try to get the ball over the net on to the floor of the opponent.

START/ FIRST BALL

The ball can be served underhand over the net from **any place** in the court. The ball may touch the net.

RULES

1. After a player throws the ball over the net, the whole team rotates one position clockwise.
2. The players are not allowed to walk with the ball.
3. The ball may touch the net.
4. When a player drops the ball or, throws the ball out of court or, throws the ball into the net, or touches the ball before it goes out of play, this player has to leave the court and take his/her place next to the court.
5. When the ball is thrown on the floor by an opponent, the player closest to that ball has to leave the court.
6. If there are only two players left in the court, these players switch places every time the ball is thrown over the net into the opponent's court.
7. A player can re-enter the court when the team mates catches the ball three times in a row.
8. All players can re-enter the court when a team mate plays **the ball with the forearm pass** and catches it him/herself.
9. The player that was out of court the longest; returns first and begins closest to the net.
10. When all opponents are removed from the court, the team left scores 1 point.

WHEN IS THE GAME DEAD?

The game is dead when the ball is not caught, which means.:

- the ball is thrown out;
- a player dropped the ball;
- the ball was thrown into the net;
- the ball was thrown onto the floor in the opponents court.
- the forearm pass failed.

WHAT HAPPENS WHEN THE GAME IS DEAD?

The game is resumed immediately by an underhand serve closest to the place where the game stopped. The server is not allowed to walk with the ball before serving.

Circulationvolleyball - level 2



(underhand serve)

The graphics show: formation and way of rotation after the ball has crossed the net when the court is filled with four, three or two players.

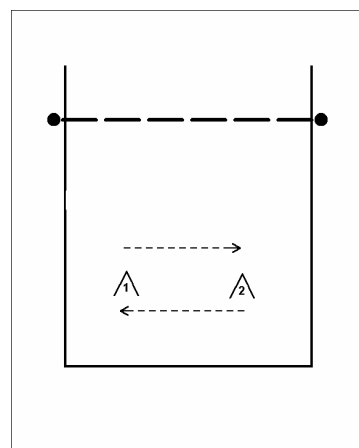
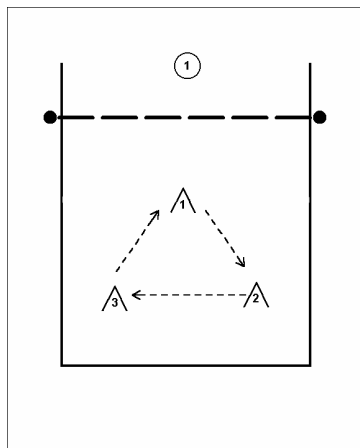
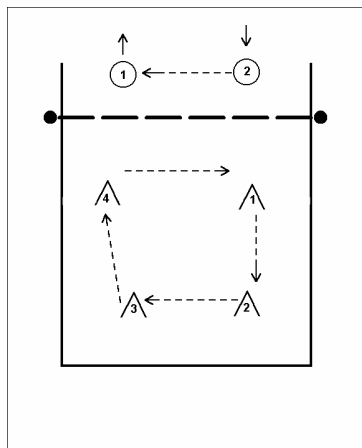

SCORE

When the opponents court is empty the winning team gets a point. The game starts again with 4 against 4 players. Before the match one should determine if a match is played to reach a score or that a timelimit is set.

GOALS

1. Were the players at level 1 busy with throwing and catching, from level 2 they have to learn to direct the ball, playing the ball to empty spaces of the opponents court.
2. The ballcirculation must become quicker, the speed of playing become higher.
3. Further the players learn orientation in time, space and trajectory, also known as timing. Players automatically get timing by contionously solving the different movementsituations by doing.
4. Increasing mobility through variations in starting postures and playing postures.
5. Learning the underhand service, by which is important the correct technical performance and the number of mistakes are low because one can serve anywhere from the own courthalve.
6. When the underarm-pass and overhead-pass get a steady shape, the player can also throw the ball with one hand above his/her head, this as a preparation to the tip-ball.

- Playing the ball with a goal
- timing
- quickness in acting
- mobility / footwork
- underhand serve

Circulationvolleyball – level 3



(forearm passing)

| | |
|--------------------|--------------------|
| AGE: | 8 – 9 YEARS OLD |
| NUMBER OF PLAYERS: | 4 PLAYERS PER TEAM |
| COURT: | 6 X 4½ METER |
| NET HEIGHT: | 2.00 METER |

GOAL

The players try to throw or bump the ball over the net on to the court of the opponents.

START/ FIRST BALL

The ball can be served underhand over the net from **any place** in the court. The ball may touch the net.

RULES

1. After a player throws or served the ball over the net, the whole team rotates one position clockwise.
2. The players are not allowed to walk with the ball.
3. The ball may touch the net.
4. Every ball from the other side of the net must play with the forearm pass to a team mate who is catching the ball and throw it directly over the net.
5. When a player drops the ball or, throws the ball out of court or, throws the ball into the net, failed to play the ball with a forearm pass or touches the ball before it goes out of play, this player has to leave the court and take his/her place next to the court.
6. When the ball is thrown on the floor by an opponent, the player closest to that ball has to leave the court.
7. If there are only two players left in the court, these players switch places every time the ball is thrown over the net into the opponent's court.
8. When all opponents are removed from the court, the team left scores 1 point.
9. A player may **re-enter** the court when a **team-mate catches a ball from a forearm pass**, or when there is only one player left, this last player makes a forearm pass and catches it him/herself.
10. The player that was out of court the longest; returns first and begins closest to the net.

WHEN IS THE GAME DEAD?

The game is dead when the ball is not caught, which means:

- the ball is thrown out;
- a player dropped the ball;
- the ball was thrown into the net;
- the ball was thrown onto the floor in the opponents court.
- A forearm passed ball is not caught by the own team. In this case the player who had to be able to catch that forearm pass leaves the court, except when the pass was really bad, then the passer has to leave the court.

WHAT HAPPENS WHEN THE GAME IS DEAD?

The game is resumed immediately by an underhand serve closest to the place where the game stopped. The server is not allowed to walk first with the ball before serving.

Circulationvolleyball - level 3



(forearm passing)

The graphics show: formation and way of rotation after the ball has crossed the net when the court is filled with four, three or two players.

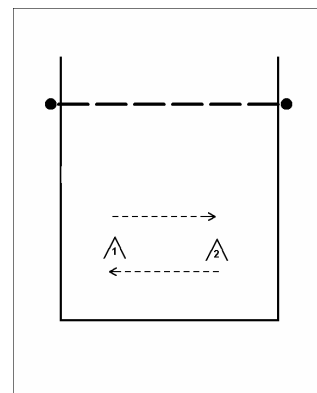
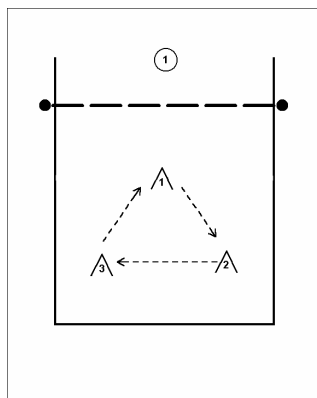
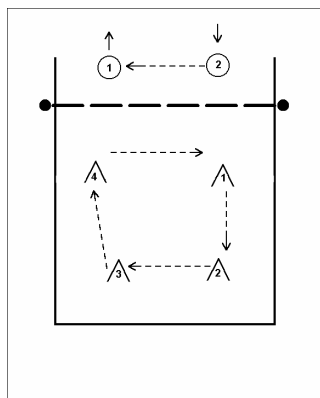

SCORE

When the opponents court is empty the winning team gets a point. The game starts again with 4 against 4 players. Before the match one should determine if a match is played to reach a score or that a timelimit is set.

GOALS

1. Good mobility to be able to play a forearm pass, where running and shuffle (joining steps) are the most suitable movements.
 2. Feet are spread and broad, a low body-posture for optimum balance.
 3. To be able to play the ball in front as well as next to the body.
 4. Combine the correct feet-position with the point where the ball is played in respect of the body.
 - ballcontact in front of the body = broad side-by-side position.
 - ballcontact to the left of the body = broad side-by-side position with rightfoot in front.
 - ballcontact to the right of the body = broad side-by-side position with leftfoot in front.
 5. The tilting of the shoulders because of the angle in which the ball has to be played.
- Movements running and shuffle.
 - Broad side-by-side position of the feet at ballcontact.
 - Correct positioning of the pass-sheet of your arms.

Circulationvolleyball - level 4



(it is mandatory to play the second ball in a smooth catch-trow movement)

| | |
|--------------------|--------------------|
| AGE: | 9 - 10 YEARS OLD |
| NUMBER OF PLAYERS: | 4 PLAYERS PER TEAM |
| COURT: | 6 X 4½ METER |
| NET HEIGHT: | 2.00 METER |

GOAL

The players try to get the ball over the net on to the floor of the opponent. Circulation volleyball becomes Mini volleyball

START

The ball has to be played with an underhand-serve over the net from behind the serve-line, the ball may touch the net.

RULES

1. The ball has to be played three times before crossing the net.
2. The second ball contact is a mandatory **non-interrupted** catch-throw-movement or catch-bump movement. This can be done in three ways:
 - With extended arms forwards.
 - With extended arms backwards, throwing overhead.
 - Catching the ball with extended arms above the head, bending knees and pushing upwards.

It's not allowed to walk or to turn around during the catch-throw-movement. The player can make only two steps.



3. It is not allowed to throw the second ball over the net.
4. It is allowed to smash the third ball, but this will be learn at Level 6.
5. When a player has made three serves in a row the team rotates and the next player has to serve.
6. The extra players are obliged to re-enter the game at the serve-spot.

Circulationvolleyball - level 4



(it is mandatory to play the second ball in a smooth catch-trow movement)

SCORE

Rallypoint: every mistake is a point to the opponent.

MOTIVATION

The second ball is the most difficult in this stage of the player's development, because playing the overhead pass and the forearm pass on an angle is difficult. The chance of mistakes is increased and the game has to be stopped many times. Through using the catch-throw or catch-bump method for the second ball, the rally can be continued. Stimulate the players to play the second ball parallel to the net; the last player can then step towards the net/ball before playing it with an overhead pass

GOALS

1. New: forward overhead pass to a team-mate (practice).
 2. Playing together in a triangle, where the second ball is played parallel to the net. The player who stands to the left or the right on the court can/should step towards the ball to be able to play the ball over the net.
 3. Playing in angles. When a player has to play the ball to the left (from the view of the player), his/her left foot has to be in front. An angle to the right means of course that his right foot should be in front.
 4. Serving over greater distance, from behind the serve-line.
- Playing together / 3 times
 - Correct foot-position at ball contact.

Circulationvolleyball - level 5



(continious playing from receiving an underhand serve)

| | |
|--------------------|--------------------|
| AGE: | 10 - 11 YEARS OLD |
| NUMBER OF PLAYERS: | 4 PLAYERS PER TEAM |
| COURT: | 6 X 6 METER |
| NET HEIGHT: | 2.00 METER |

GOAL

Players try to play to the ball over the net by using an overhead pass or forearm pass onto the court of the opponent.

RULES

1. The players are not allowed to catch any ball, they have to play the ball with short contact.
2. The team is allowed to play the ball with a maximum of three short contacts, after that the ball has to cross the net to the court of the opponent.
3. A team can get a bonus point when they're playing the ball together in three times. The bonus point is counting directly to the score. The bonus point doesn't count when the third ball is playing wrong.
4. It is allowed to smash the third ball, but this will be learn at Level 6.
5. The extra players are obliged to re-enter the game at the serve-spot.
6. When a player has made three serves in a row the team rotates and the next player has to serve.

START

The ball has to be played with an underhand-serve over the net from behind the service line, the ball may touch the net.

SCORE

Rallypoint: every mistake is a point to the opponent.

GOALS

1. Convert catch-throw movement in to overhead pass forwards or backwards.
2. New: overhead pass backwards (practise).
3. Team work, means playing in angles; overhead pass as well as forearms pass.
4. Quick moving towards the ball and correct feet-position at ball contact, playing at an angle to the right or the left.
5. Forearm passing:
 - to the left = left-foot in front and playing the ball at the right side of the body.
 - to the right = right-foot in front and playing the ball at the left side of the body.
- Forearm pass at an angle to the right = right-foot in front/ playing the ball on the left side in front of the body / bring the right-shoulder down.
- Forearm pass at an angle to the left = right-foot in front/ playing the ball on the right side in front of the body / bring the left-shoulder down.

MOTIVATION

The serve at level 5 is mandatory and is to be played underhand, so the receiving team is able to build a rally. The chance that a game flows continuously is greater when the number of ball contacts increases.

Circulationvolleyball - level 6



(continuous playing)

| | |
|---------------------------|---------------------------|
| AGE: | 11 - 12 YEARS OLD |
| NUMBER OF PLAYERS: | 4 PLAYERS PER TEAM |
| COURT: | 6 X 6 METER |
| NET HEIGHT: | 2.00 METER |

GOAL

The players try to play the ball over the net on to the court of the opponent by means of the overhead pass, the forearm pass or by an attack (smash; from standing position or, push ball or a smash with approach).

START

The ball has to be played with an underhand-serve or overhead serve over the net from behind the service line, the ball may touch the net.

RULES

1. The players are not allowed to catch the ball; they have to play the ball with short contact.
2. The team is allowed to play the ball with a maximum of three contacts, after that the ball has to cross the net to the opponent's court.
3. The extra players are obliged to re-enter the game at the service point.
4. When a player has made three serves in a row the team rotates and the next player has to serve.
5. A jump serve is allowed.

SCORE

Rallypoint: every mistake is a point to the opponent.

GOALS

1. New: overhead serve (practise).
 2. New: smashing/hitting technique - approach - take-off - timing of the attack (practise).
 - forearm playing at an angle (left/right).
 - overhead pass; forwards and backwards at angles.
- Make a transition from throwing overhead and serving / attack.
 - Righthanded = left-foot in front / lefthanded = rightfoot in front.
 - Balance.
 - Attention to tossing the ball.