

# VANCOUVER SKYTRAIN

## Infrastructure Case Study

Derek Wong

ARCH 544U

Fall 2015

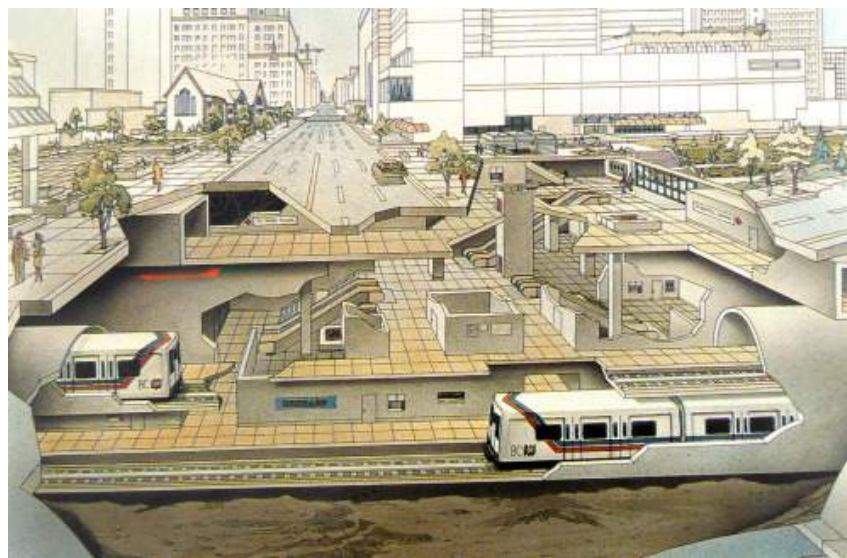

Ron Love

# Monospan Twin-Ride System (MTRS)

Wells Coates, 1957

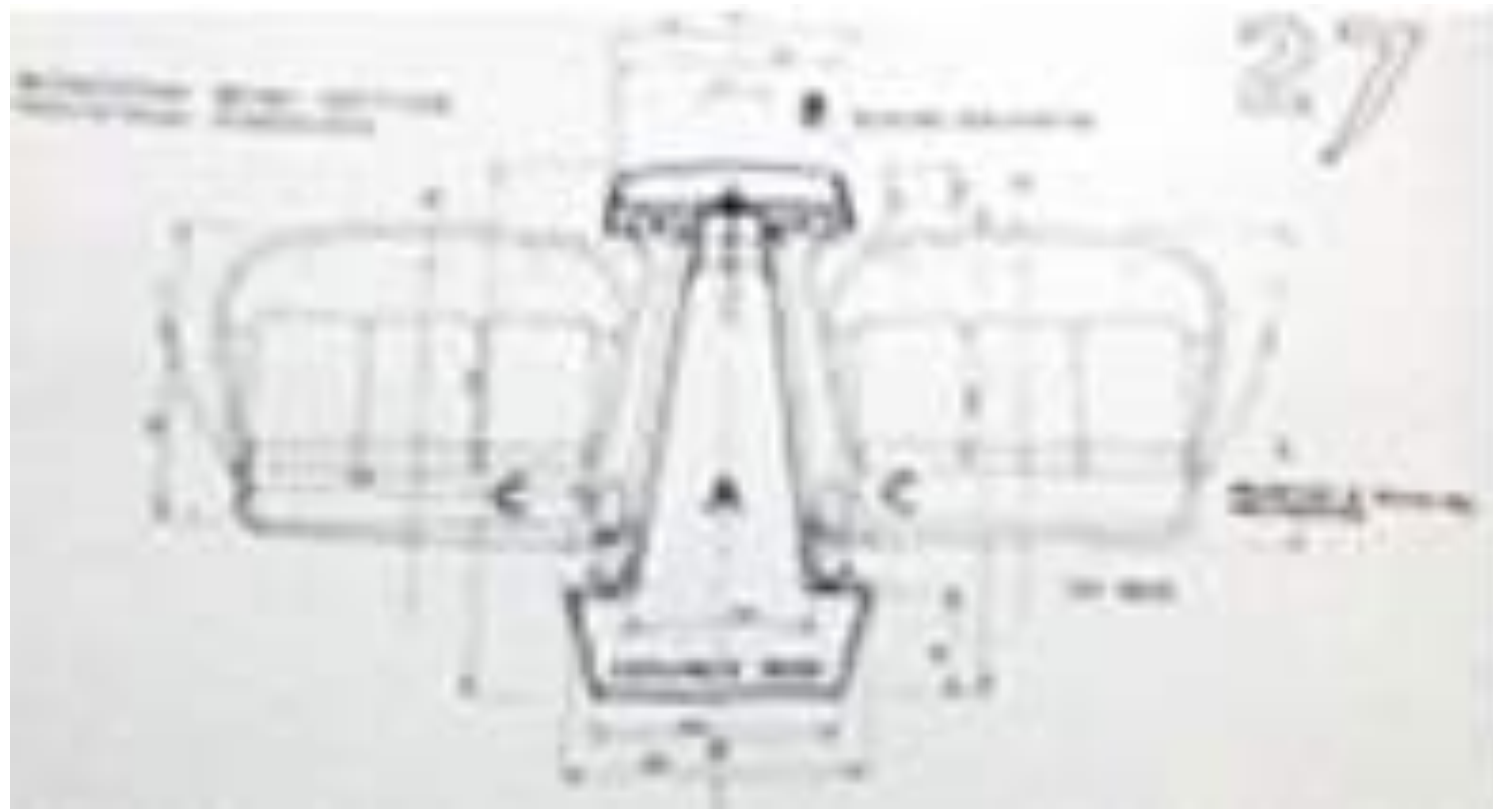



# Expo 86

World Exposition on Transportation and Communication, 1986  
Land, Air, Water



# Expo Line

Demonstration Line, 1983

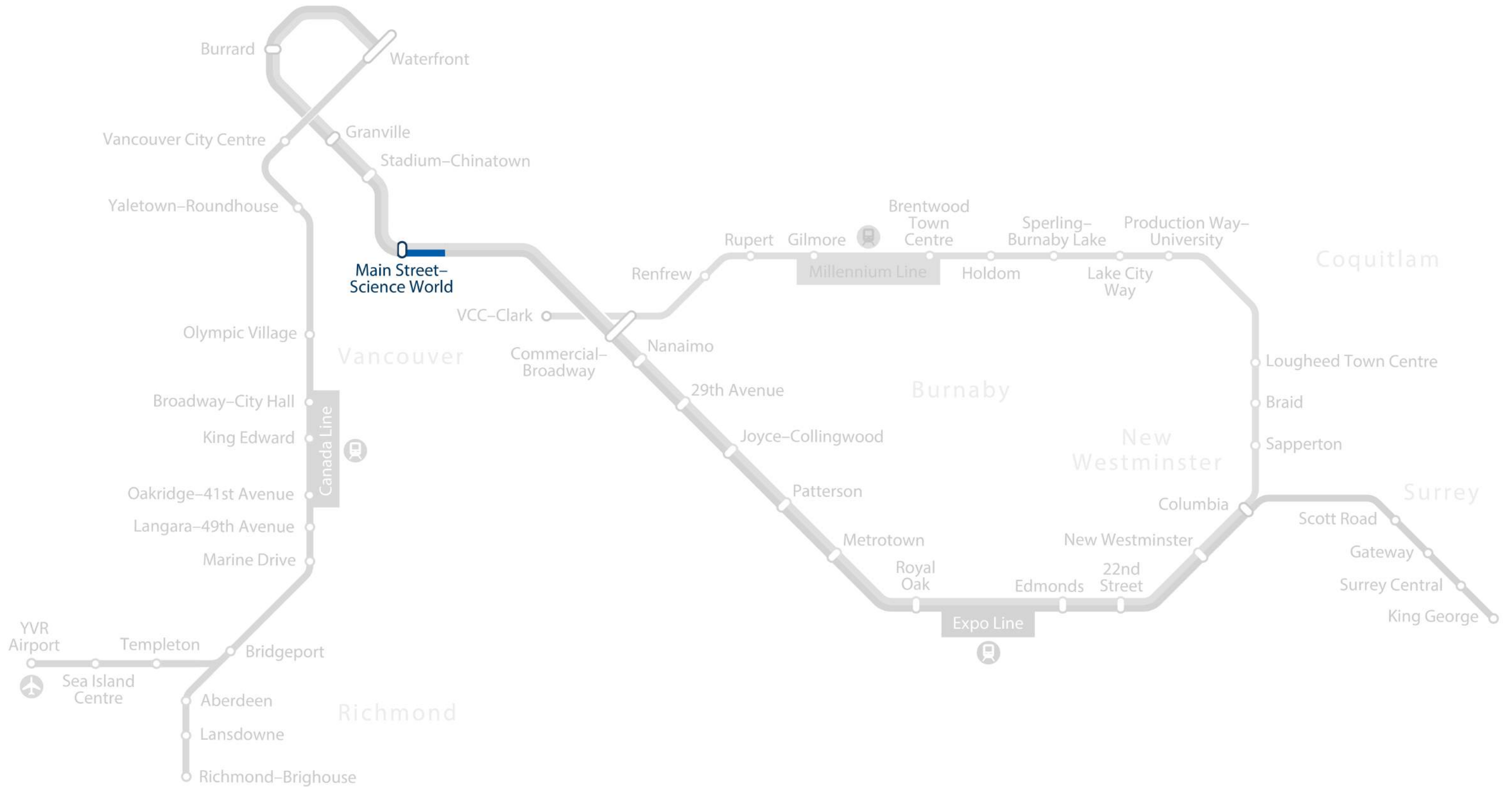



# Expo Line

Phase I Original Expo Line, 1981 - 1986

Length: 21.4km  
 Started Construction: 1981  
 In Service: 1986  
 Cost: \$854.3m (1986)  
 Cost: \$1,601.15m (2012)  
**Cost per km: \$74.8m (2012)**

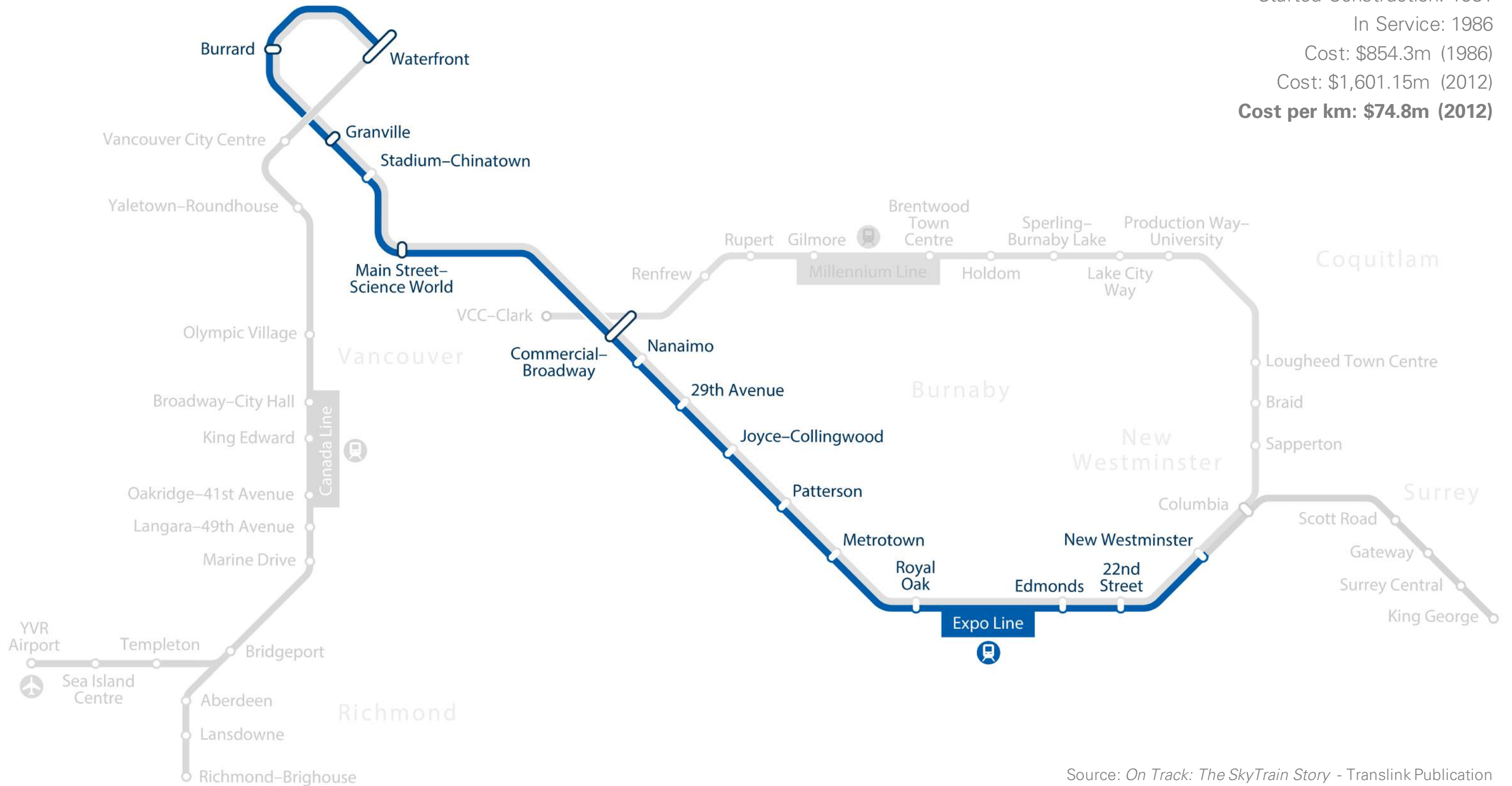

Source: *On Track: The SkyTrain Story* - Translink Publication

# Expo Line

Phase II Columbia to Scott Road, 1986 - 1990

Length: 3.1km  
 Started Construction: 1986  
 In Service: 1990  
 Cost: \$179m (1990)  
 Cost: \$281.69m (2012)  
**Cost per km: \$90.9m (2012)**

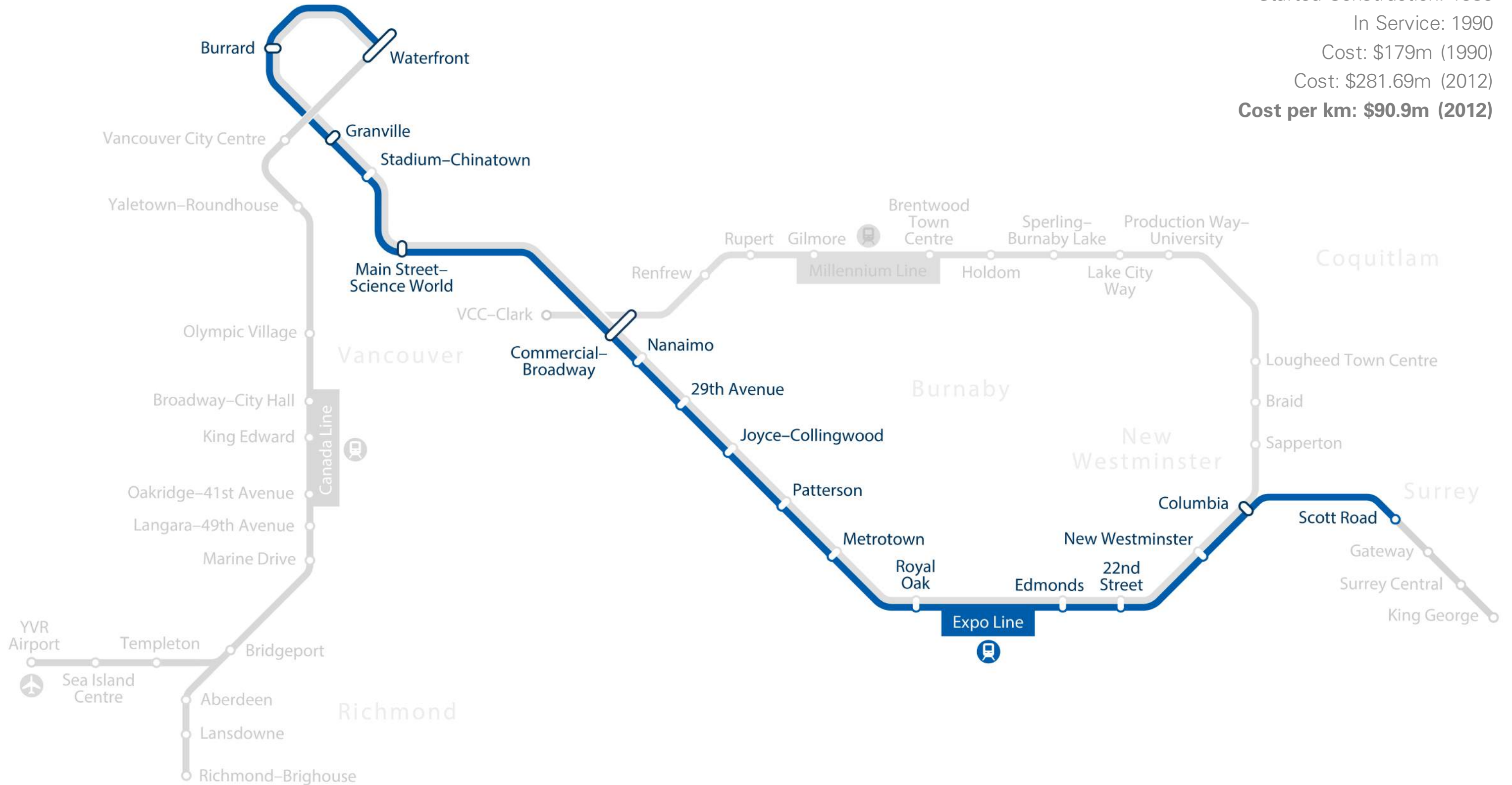

# Expo Line

Phase III Scott Road to King George, 1990 - 1994

Length: 4.4km  
 Started Construction: 1990  
 In Service: 1994  
 Cost: \$148m (1994)  
 Cost: \$207.48m (2012)  
**Cost per km: \$47.1m (2012)**

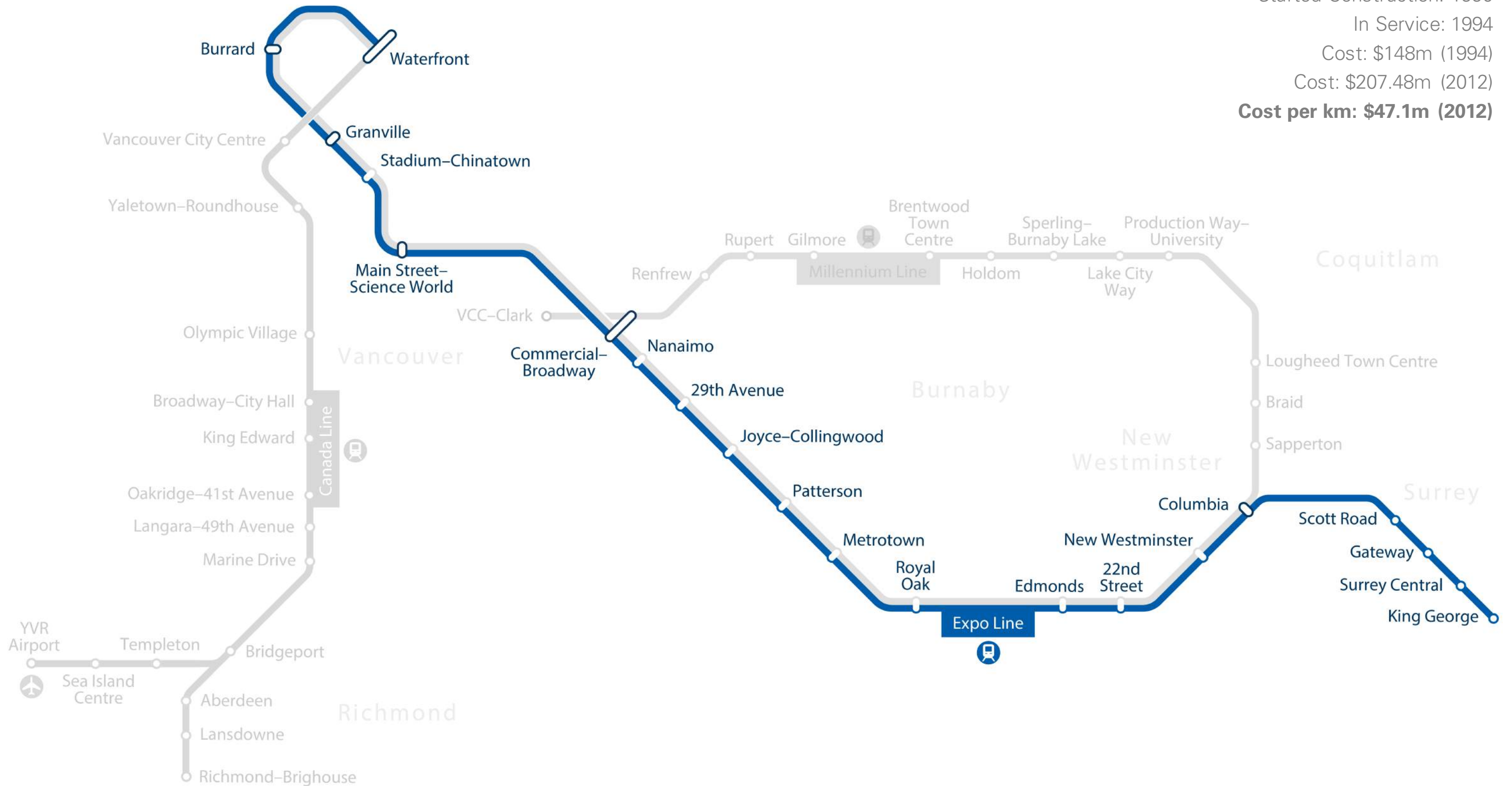

# Richmond – Vancouver Connection

Route Options, 1989 - 1993

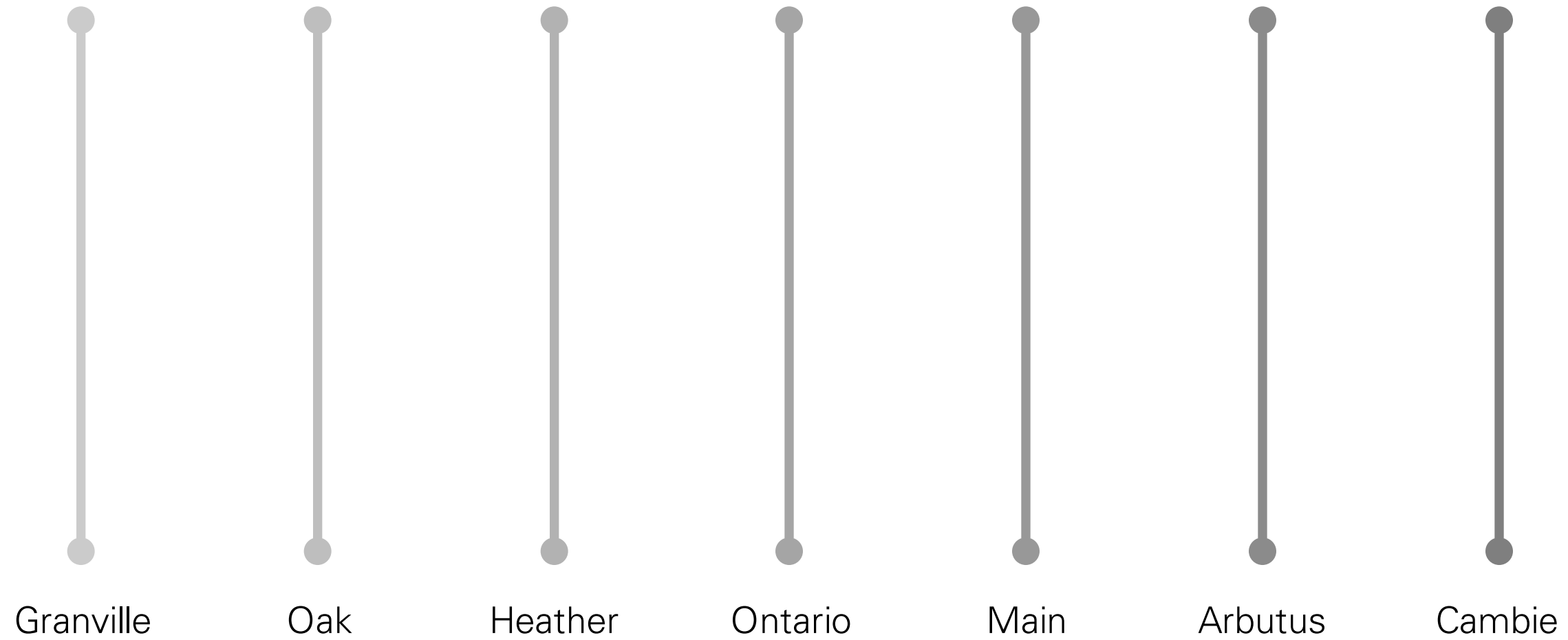



# Millennium Line

Phase IV/V, 1999 - 2002

Length: 20.5km  
Started Construction: 1999  
In Service: 2002  
Cost: \$1,167m (2002)  
Cost: \$1,443.21 (2012)  
**Cost per km: \$70.4m (2012)**

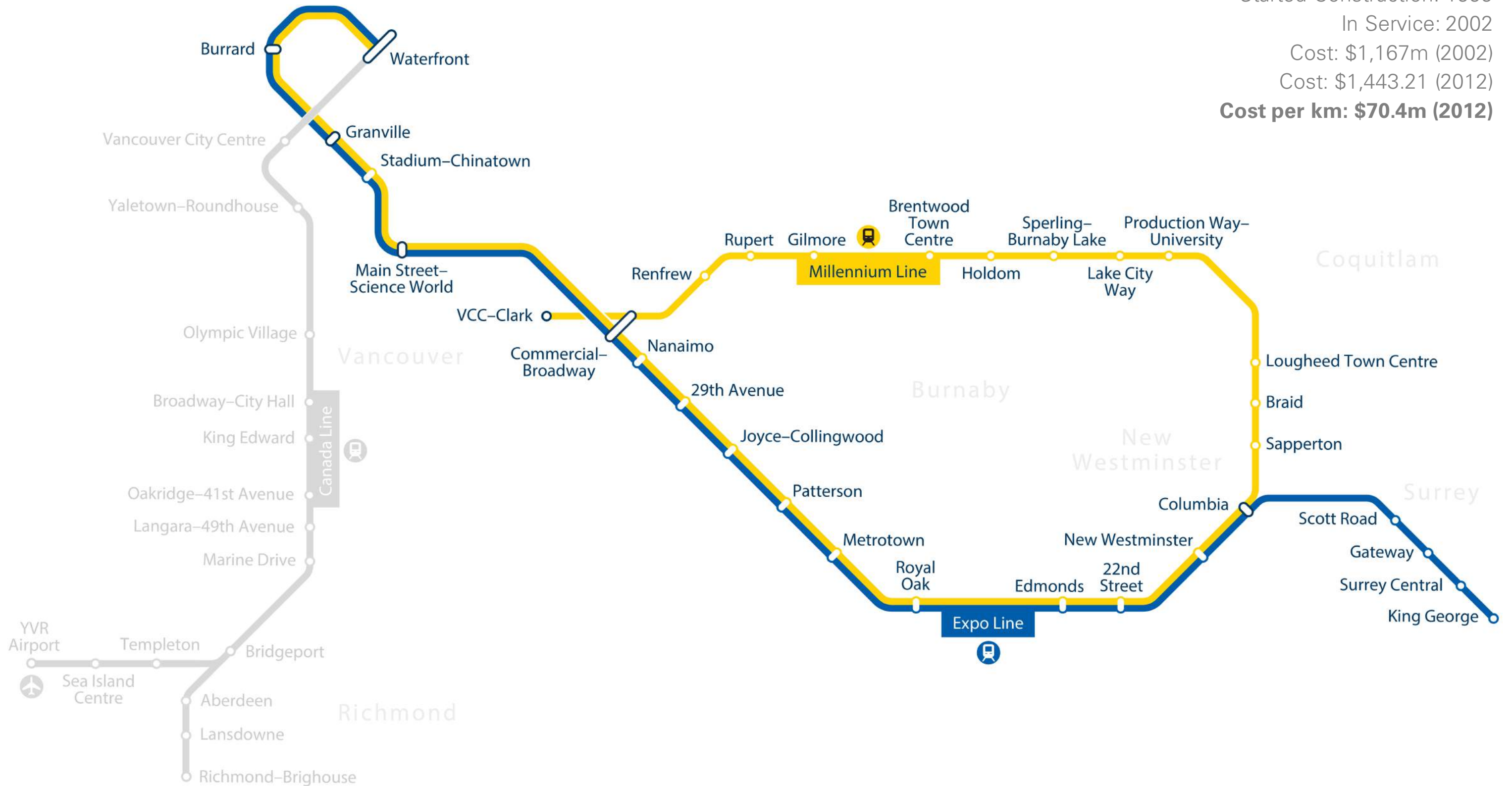

# Urban Density

1991 – 2001

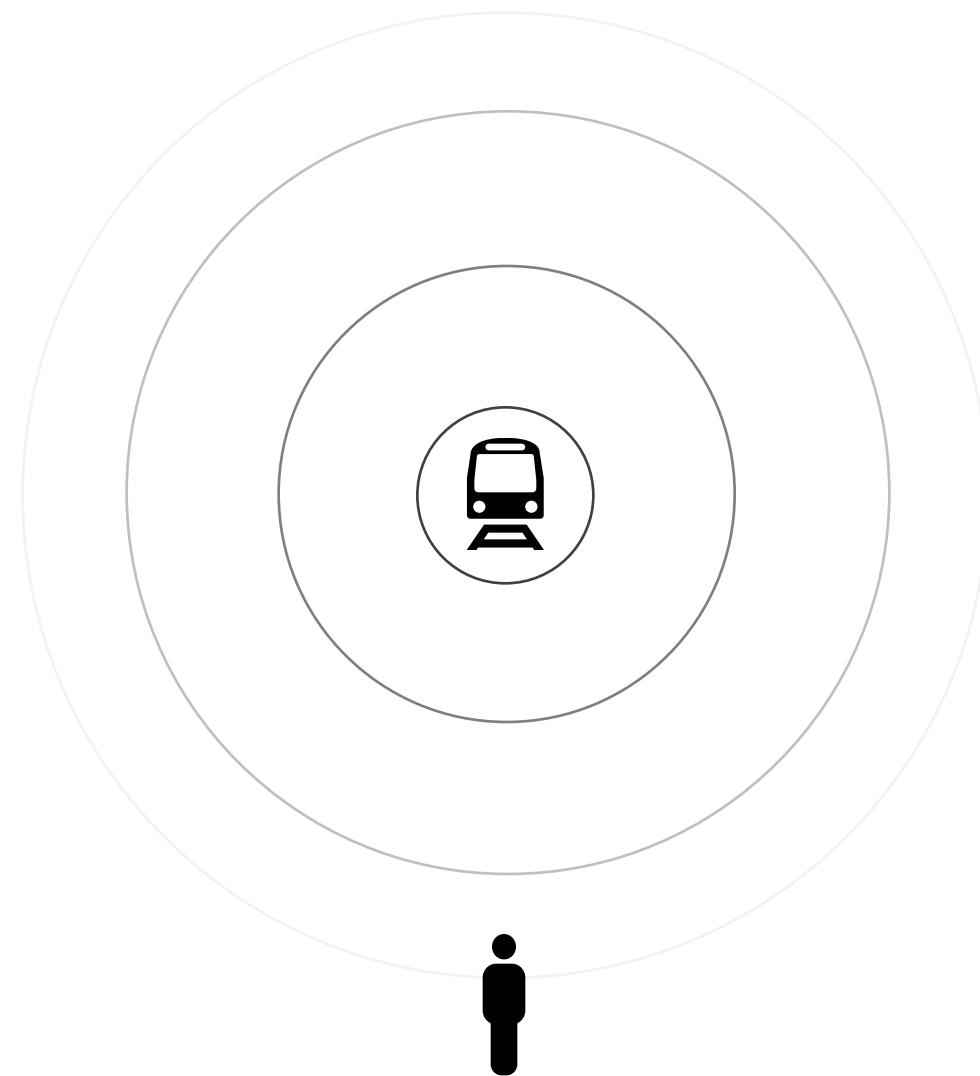

Population living within 500m of SkyTrain, increased by 37%  
400K to 1.3M people

Source: *Making the Connection to a World of Choice*. TransLink.

# Lougheed Town Centre

2000 – 2002 – 2005

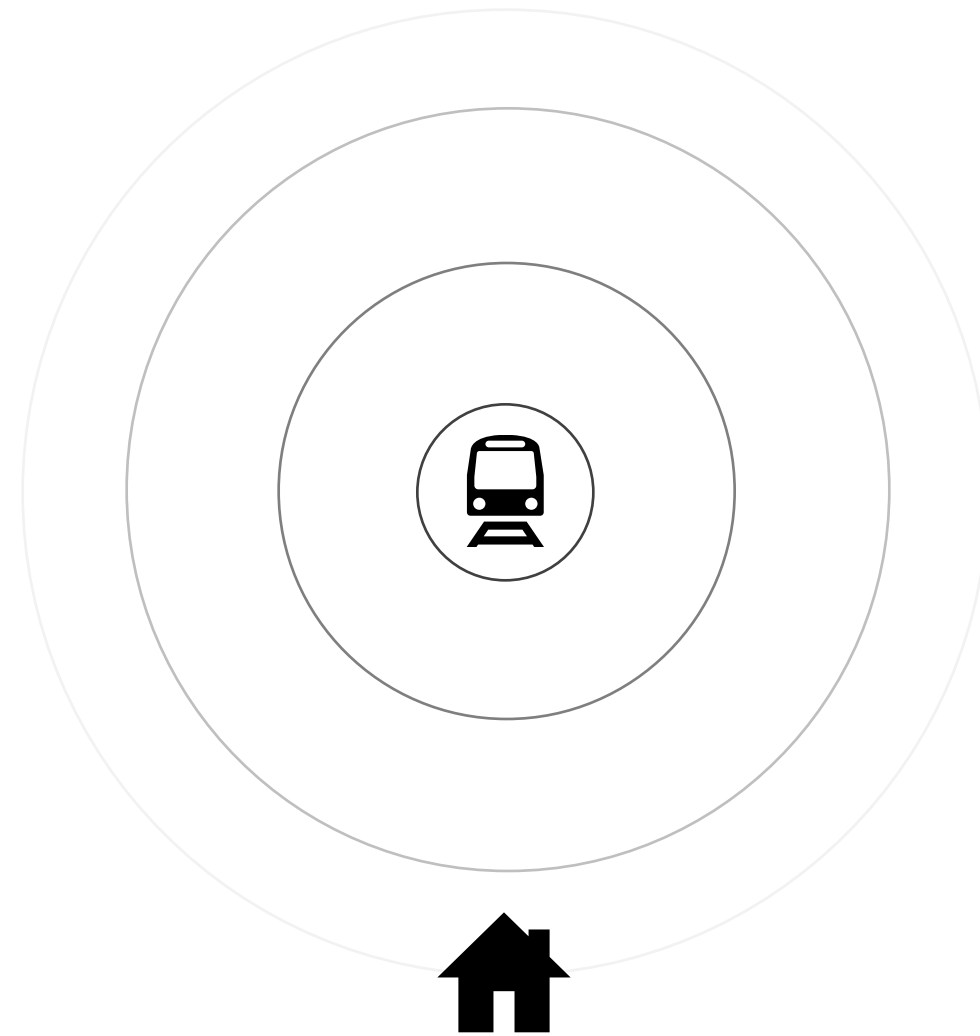

Property values decreased during construction  
Effect disappeared upon opening and after 3 years of operation  
Returned back to variables such as floor space  
Proximity to schools no longer a factor



# Demographics Shift

1981 – 2006 Census

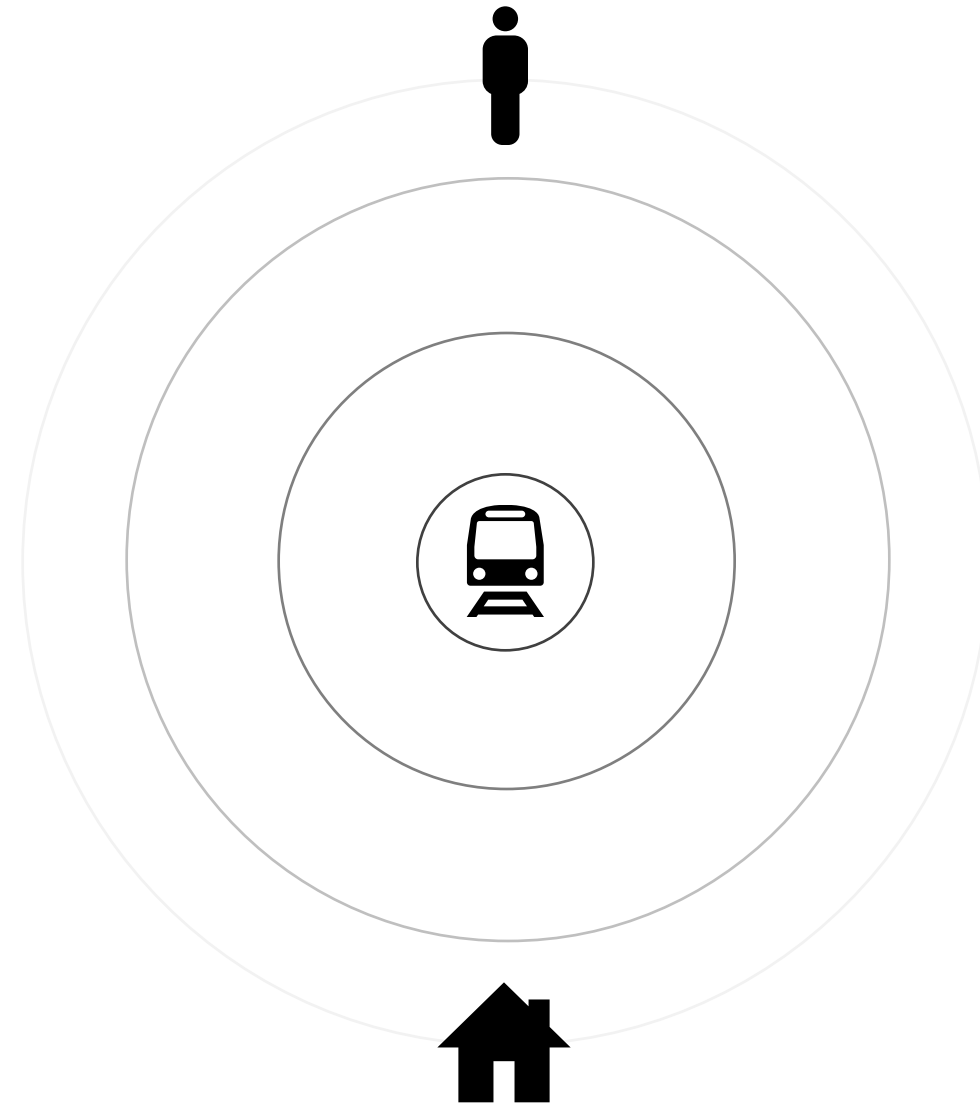

Neighbourhoods near stations have become physically denser, wealthier and more educated compared to Vancouver as a whole

# Demographics Shift

Low Income Housing

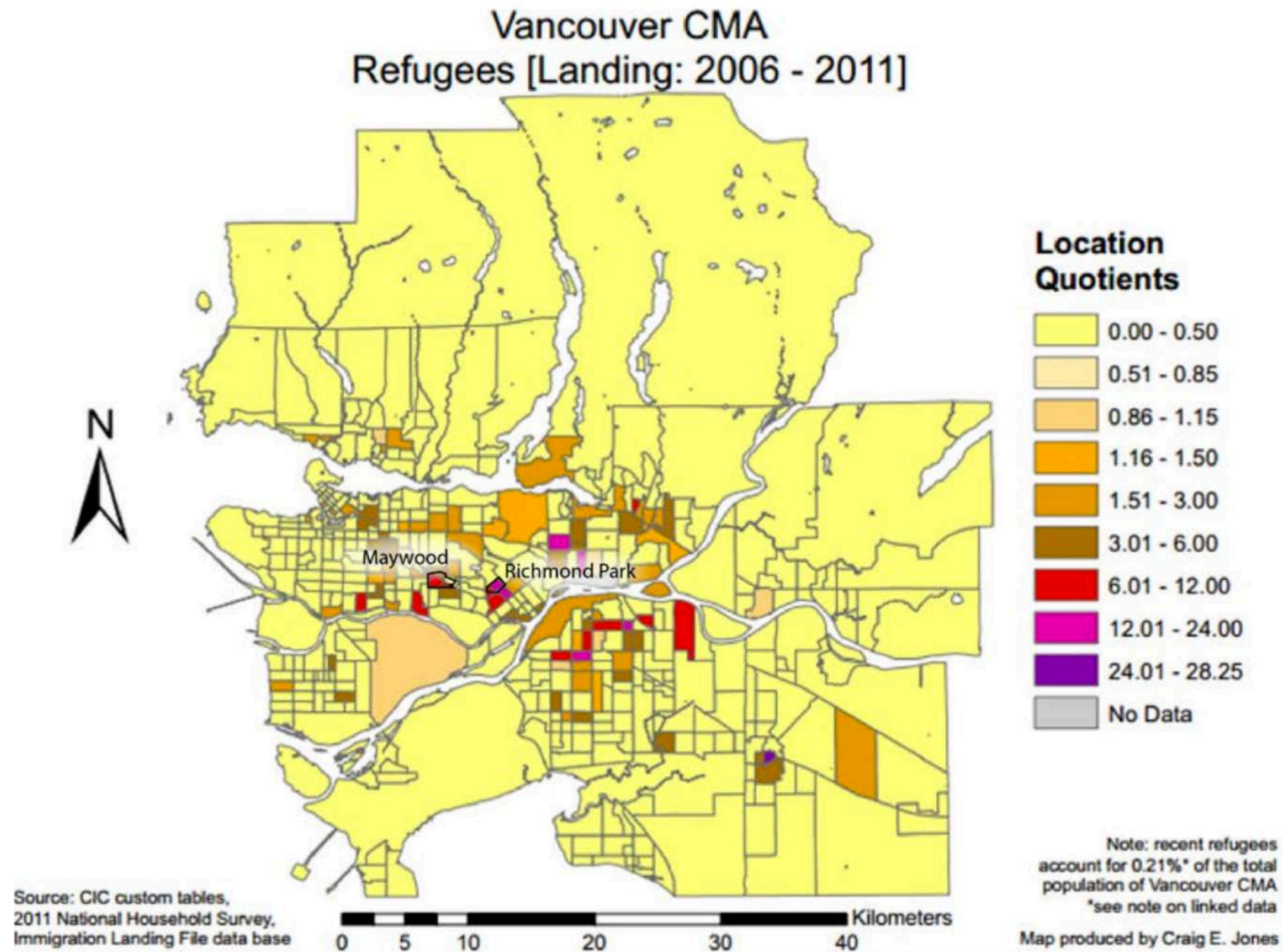



# Demographics Shift

Low Income Housing

## Average Individual Income, Vancouver Census Metropolitan Area, 2010

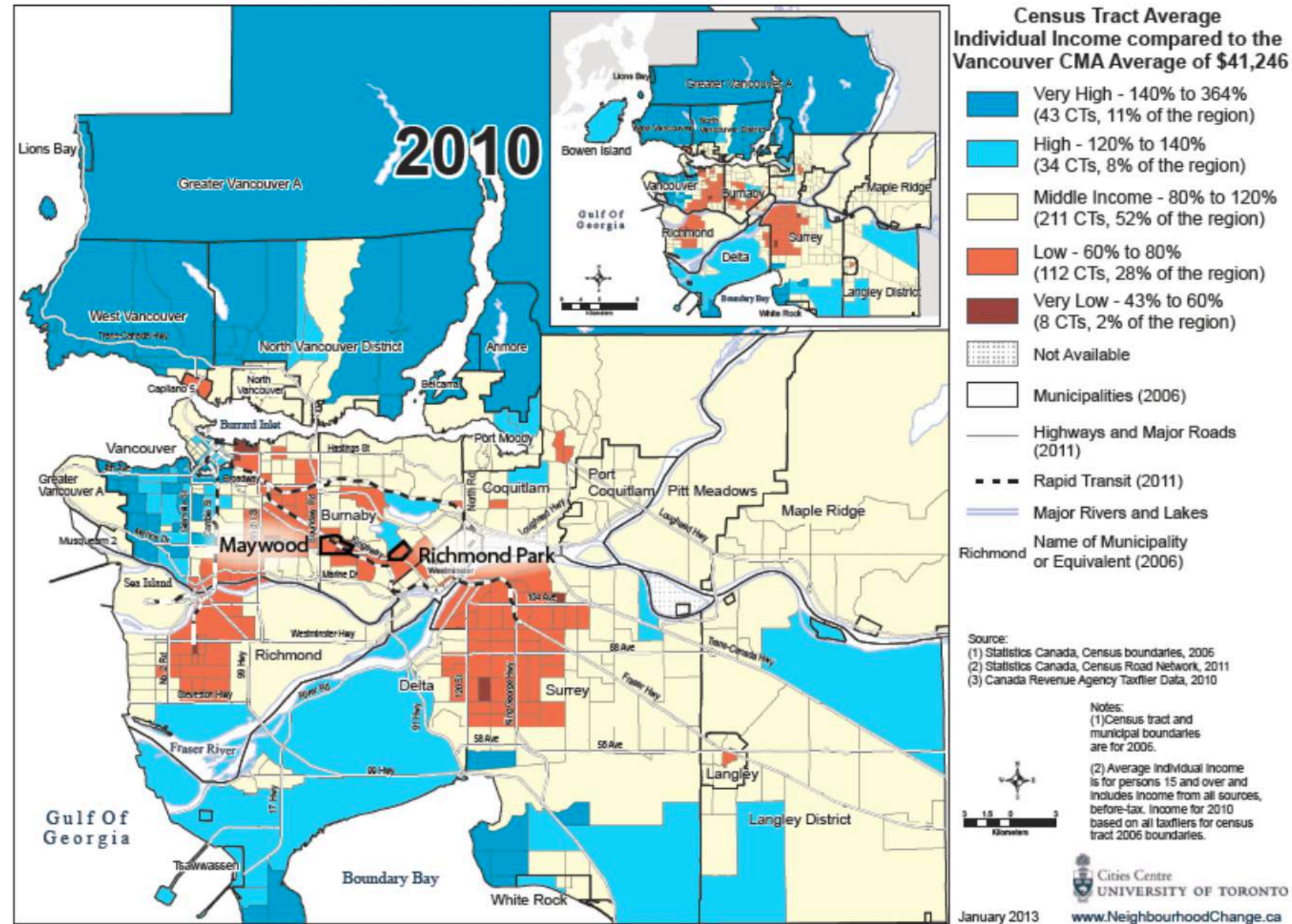



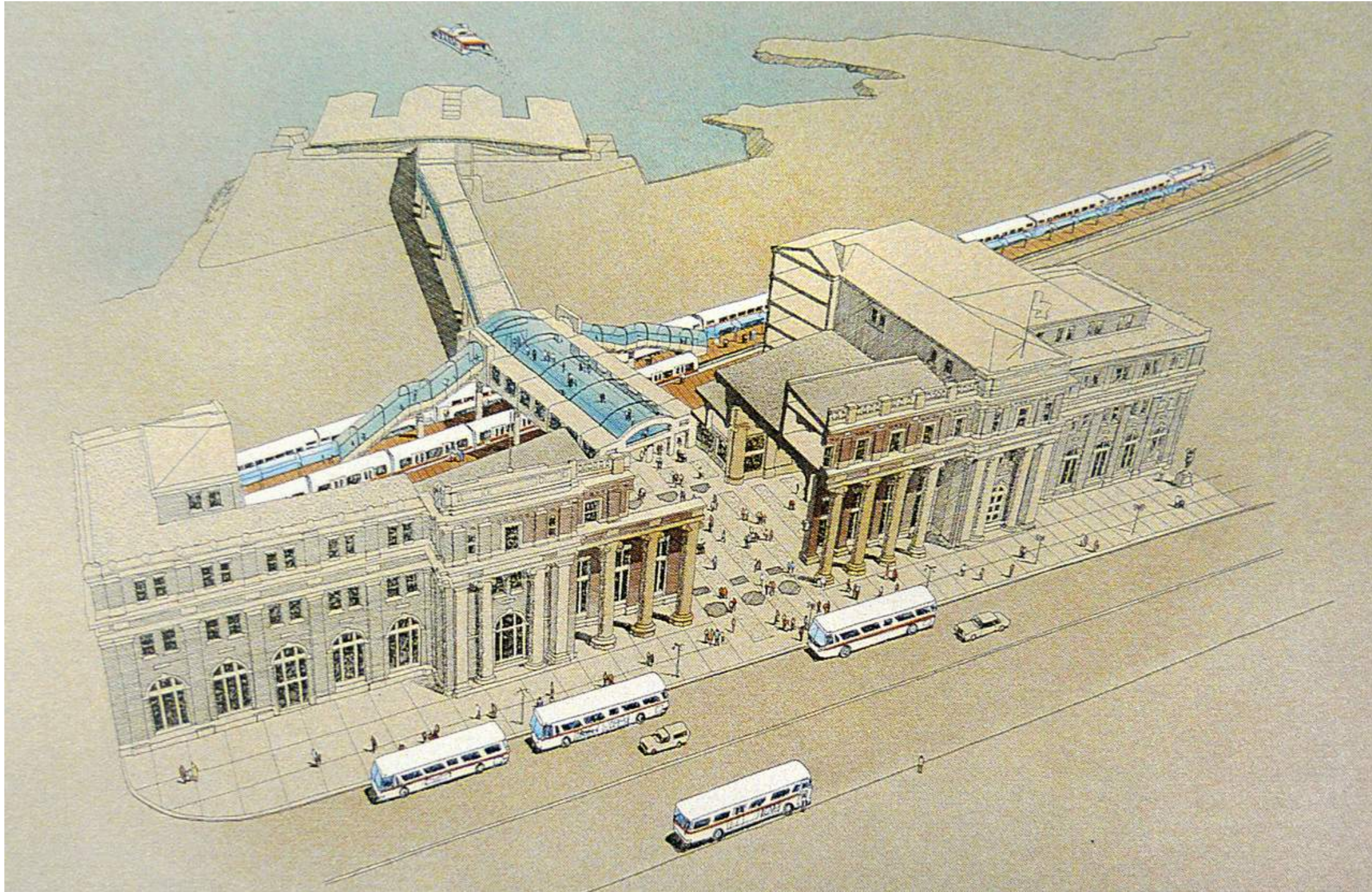

Ron Love



