

UNIVERSITY OF BRITISH COLUMBIA

**D-CONSTRUCTED  
TOOL GLOSSARY**

MATERIALS • TOOLS • PROCESSES

23	<b>A</b> ADDITIVE MANUFACT.	21	POLAR
		66	PROFILE SCANNER
	<b>C</b>		<b>R</b>
18	CARTESIAN	59	ROTOMOLDING
43	CNC LATHE		<b>S</b>
44	CNC MILL	20	SCARA
53	CNC PRESS BRAKE	38	STEREOLITHOGRAPHY
54	CNC PUNCH PRESS		APPARATUS (S.L.A.)
55	CNC ROLLER	25	SUBTRACTIVE MANUFACT.
45	CNC ROUTER	37	SELECTIVE LASER MELTING
56	CNC TUBE BENDER		(S.L.M.)
09	CONCEPTS	58	SINGLE POINT FORMING
16	CUTTING TOOLS		(S.P.F.)
	<b>D</b>	67	STRUCTURED-LIGHT
19	DELTA		<b>T</b>
12	DEGREES OF FREEDOM	14	TOOL PATH
	<b>E</b>		<b>V</b>
49	EDM	57	VACUUM FORMING
	<b>F</b>		<b>W</b>
07	FOREWORDS	48	WATER JET CUTTER
27	FORMATIVE FABRICATION	49	WIRE EDM
35	FUSED DEPOSITION MODELING (F.D.M.)	13	WORK ENVELOPE
	<b>H</b>		<b>#</b>
31	HYBRIDS	10	2D
	<b>L</b>	11	3D
36	LAMINATED OBJECT MANUFACTURING (L.O.M.)	68	3D BODY SCAN
63	LIDAR	39	3D INK JET
	<b>I</b>	12	6-DEGREES OF FREEDOM
60	INJECTION MOLDER		
61	INPUT		
	<b>K</b>		
15	KINEMATICS		
	<b>M</b>		
64	MOTION CAPTURE		
	<b>P</b>		
14	PATH		
65	PHOTOGRAMMETRY		
47	PLASMA CUTTER		

03	<b>GLOSSARY</b>	48	WATER JET CUTTER
		49	WIRE EDM
05	<b>TABLE OF CONTENT</b>		
07	<b>FOREWORDS</b>	51	<b>FORMING</b>
		53	CNC PRESS BRAKE
		54	CNC PUNCH PRESS
		55	CNC ROLLER
		56	CNC TUBE BENDER
		57	VACUUM FORMING
		58	SINGLE POINT FORMING
		59	ROTOMOLDING
		60	INJECTION MOLDING
		61	<b>INPUT</b>
		63	LIDAR
		64	MOTION CAPTURE
		65	PHOTOGRAMMETRY
		66	PROFILE SCANNER
		67	STRUCTURED-LIGHT
		68	3D BODY SCAN
		71	<b>ACKNOWLEDGMENTS</b>
33	<b>ADDITIVE MANUFACT.</b>		
		35	FUSED DEPOSITION MODELING (F.D.M.)
		36	LAMINATED OBJECT MANUFACTURING (L.O.M.)
		37	SELECTIVE LASER MELTING (S.L.M.)
		38	STEREOLITHOGRAPHY APPARATUS (S.L.A.)
		39	3D INK JET
41	<b>SUBTRACTIVE MANUFACT.</b>		
		43	CNC LATHE
		44	CNC MILL
		45	CNC ROUTER
		46	LASER CUTTER
		47	PLASMA CUTTER

THE MATERIALS CHART VISIBLE ON EACH PAGE IS OFFERED AS A QUICK REFERENCE FOR MAKING DECISIONS ABOUT TOOL USE.

THERE ARE EXCEPTIONS TO EVERY RULE AND SPECIFICS FOR TOOL USE IS ALWAYS AT THE DISCRETION OF THE SHOP COORDINATOR.

## FOREWORDS

Each year, the School of Architecture and Landscape Architecture (SALA) introduces a new cohort of students to our ever-evolving ecosystem of digital and analog tools. These tools are essential to our production as designers and are used in studio work, course work, and research. SALA is driven to foster a culture of making within our school and to empower, support, and encourage, all members of SALA to work directly with tools and materials in their academic work.

To aid our mission, SALA students and faculty have created a series of printed guides, web-based guides, and video tutorials that orient and instruct new SALA shop users on the correct and optimal use of equipment in our workshops. These materials also identify where equipment can be found and accessed, and offer some of the basic terminology used in fabrication. These guides (including this D-Constructed Tool Guide) are designed to supplement teaching in the school, and will be made available to all student, staff, and faculty users of our fabrication infrastructure.

These documents were produced by the UBC School of Architecture and Landscape Architecture as part of a Large TLEF Grant titled "Integrated Design Learning through Making and Building @ SALA". We offer our sincere thanks to the Teaching, Learning, and Enhancement Fund grant program for their generous support.

## **TERMS & CONCEPTS**

## 2D

2D (two-dimensional) describes a space within a single plane, usually measured by Euclidean or Cartesian coordinates (X & Y). Tools like the laser cutter work in 2D space. They do not move up and down.

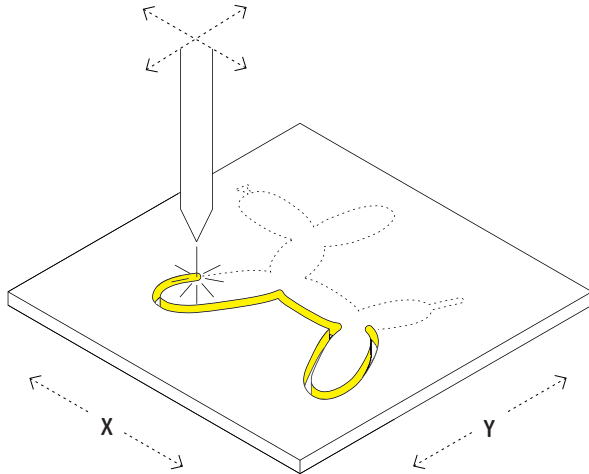

## 3D

3D (three-dimensional) describes a space in which three values (parameters) are required to locate the position of an element. The three parameters are commonly referred to as the X, Y, and Z coordinates. A Computer Numerically Controlled (CNC) Mill works in 3D space.

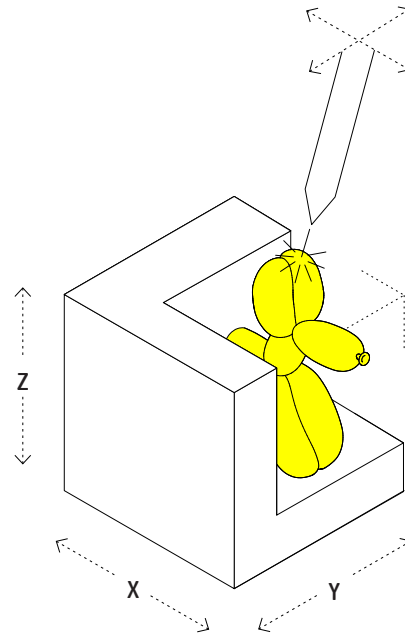

## 6-DEGREES OF FREEDOM

“Degrees of freedom” refers to the freedom of movement of a rigid body in three-dimensional space. Specifically, the body is free to change position in multiple ways. Three axial degrees of freedom (X,Y,Z) include left/right (X, sway), forward/backward (Y, surge), and up/down (Z, heave). Three additional rotational degrees of freedom (A, B, C) occur about three perpendicular axes, often termed yaw (A, rotation around the normal axis), pitch (B, lateral axis), and roll (C, longitudinal axis).

The concept of degrees of freedom is important in subtractive processes as well as robotics. A CNC Mill may have 3-degrees of freedom (cutting in the X-, Y-, and Z- axes). A more sophisticated CNC Mill might have 5-degrees of freedom. A fully articulated robotic arm will have 6-degrees of freedom. The higher the number of degrees of freedom a tool has, the more specific the work it is able to do.

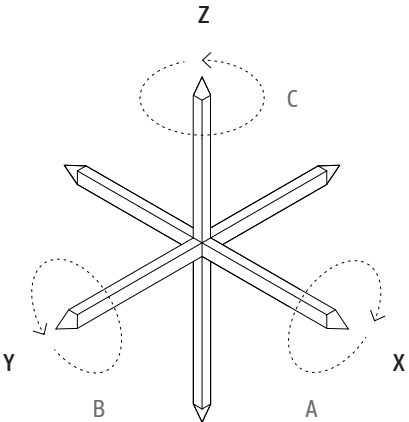

## TOOL SPACE

“Tool space” or “work envelope” represents the maximum mechanical reach of a given tool. The operative mechanism of the tool (bit, blade, print-head, etc.) is of specific concern. Tool space is typically represented as a volume and describes the space within which a selected tool can execute actions (like cutting, carving, or printing).

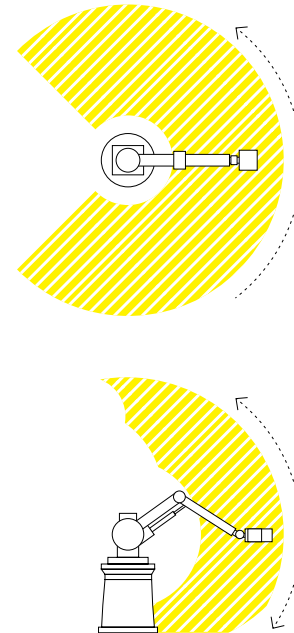

## TOOL PATH

The path the tip of a tool follows through space when producing a workpiece is called the “tool path”. This term can be applied to tools used in both additive and subtractive manufacturing. The tool path is important in fabrication. It is also a potential point of control for the designer. Paths can be specifically designed and choreographed for a variety of reasons, including a desire to control structural integrity during fabrication, the strategic deposition of materials, or for energy and time efficiency.

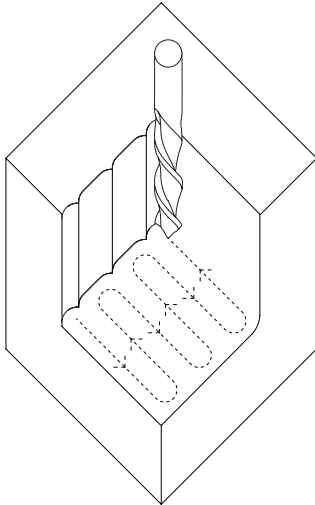

## KINEMATICS

Robot Kinematics refers to the architecture of tools and the logics of both local and relational movement within them. It is often thought of as “the geometry of movement” and is studied in both engineering and mathematics. These mechanical relationships, between points, bodies, and systems of bodies, define the movements of tools used in digital fabrication. The most common (but not exclusive) types of Kinematics in 3d manufacturing are Cartesian, Delta, SCARPA and Polar.

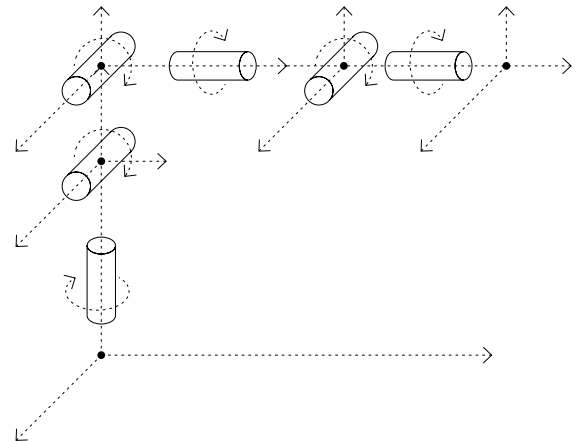



## CUTTING TOOLS

In the realm of fabrication, Cutting Tools (or cutters) includes any tool that is used to remove material from a work piece by cutting or carving. Cutting is accomplished in a number of ways. Mechanical cutting might include a “bit” or “blade”. Other forms of cutting are done with laser, plasma, and water jet. Cutting actions include milling, drilling, and grinding.

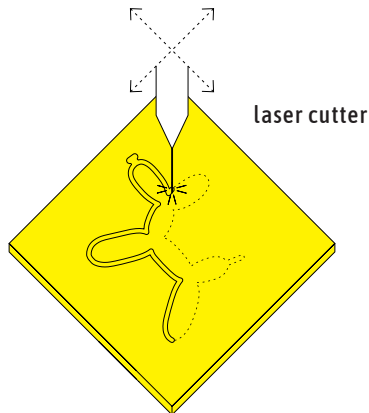

## G-CODE

G-Code is a programming language used by people to direct computerized fabrication machines. The code describes the path of the tool, its speed and direction of movement. G-Code is used in both additive and subtractive manufacturing. It is not typically written specifically by a designer. Most tools and many design software packages are capable of converting design information (computer models and drawings) into G-Code. G-Code is generated in a variety of ways. It is delivered to a computer that drives the machine selected for fabrication.

## CNC

Computer Numerically Controlled, or CNC, refers to any computerized mechanical tool used for digital fabrication. The “computer” is the processor that drives the tool. The “numeric” component is the code used to instruct the computer and to “control” the tool. An example is the CNC Mill. Although the common names of many digital tools do not contain the term “CNC” (laser cutter for example), it can be assumed that any tool that is driven by G-Code is computer numerically controlled.

## CARTESIAN

A "Cartesian" fabrication tool typically has a rectangular or box-shaped work envelope. Tool movement happens along the three Cartesian axes. For example, the build plate might move "up and down" along the Z-Axis while the print head moves freely on a gantry through the X and Y axes. Other logics are possible. Relationships between the print head and the build plate determine the specificity of the build.

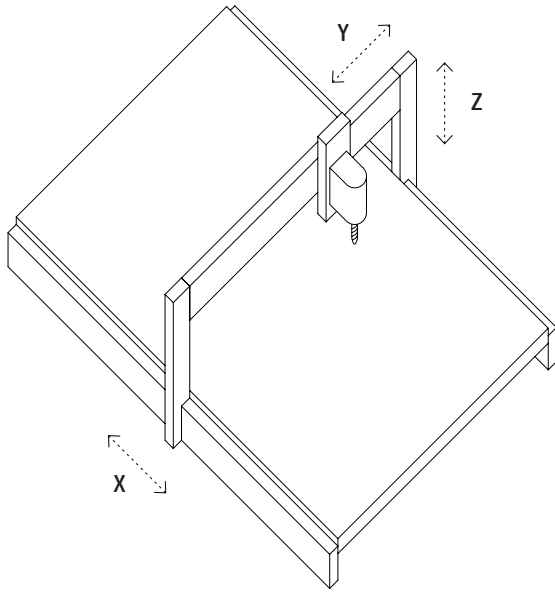

## DELTA

Delta systems typically suspend the print-head from three independently articulated arms. The "delta" gets its name from the triangulated organization of vertical columns that comprise the assembly's primary structure. Each arm only moves in the Z-axis. The relationship between the three arms allows the print-head to move freely through the x, y and z axes. The result is a system that takes less force to operate than the Cartesian system.

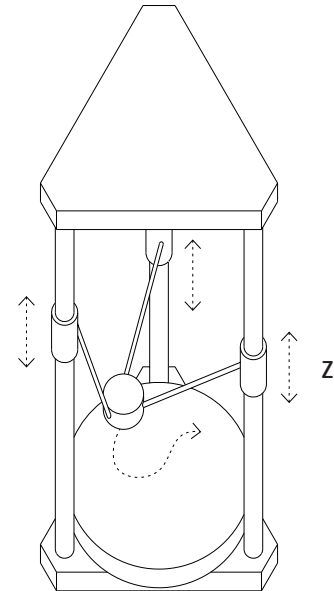

## SCARA

The “Selective Compliance Assembly Robotic Arm (SCARA)” is a very precise system with a tiny footprint. A SCARA 3D printer looks like, and moves in a manner similar to that of an industrial robotic arm. The jointed two-link arm layout includes two compliant (flexible) axes (x- and y-). The Z-Axis is rigid and only free to move up and down.

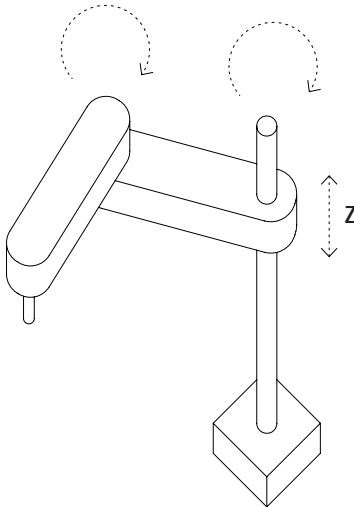

## POLAR

A Cartesian coordinate system describes points in terms of distance. Two vector distances (x- and y-) locate a given point on a plane. A polar coordinate system locates points using distance and direction. Put simply, the relationship between “over and up” is traded for “how far at a given direction”.

A polar machine is comprised of a rotating bed and a print head that moves in the X- and Z- axes. This approach generates motion in all three dimensions with fewer motors. Polar 3D printers eliminate the need for an external frame, allowing for greater build volume within a smaller space.

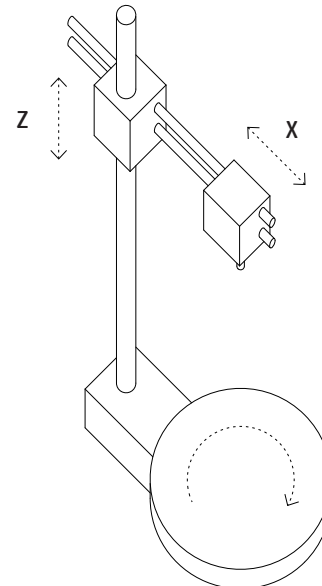

## ADDITIVE FABRICATION

“Additive fabrication” refers to computer controlled build processes where materials are deposited in layers and aggregated to construct three dimensional objects. Three dimensional design data (often generated as a digital model) is used to drive 3D printers which deposit plastics, clay, powders, or some forms of metal.

Many fabrication methods create objects through the removal of material (milling and cutting). These “subtractive” processes generate waste through material loss. Additive fabrication places specific amounts of material to produce a desired form, significantly reducing the amount of waste generated to produce a physical part. Complexity is achievable using both additive and subtractive methods, but additive fabrication has advantages. Objects with latticed or networked interiors are more easily made using additive fabrication methods for example.

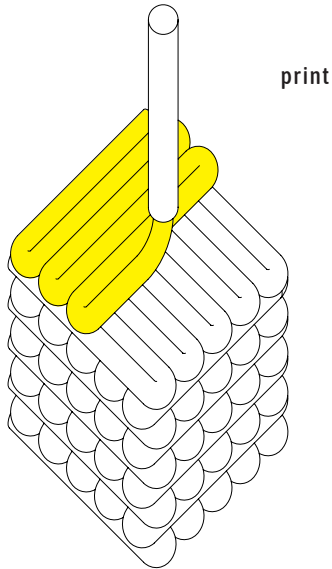

## SUBTRACTIVE FABRICATION

In subtractive manufacturing 3D objects are made by consecutively cutting material away from a fixed material body until a desired form is achieved. Unwanted materials are removed by cutting, drilling, or milling. Subtractive processes are inherently more wasteful than additive processes.

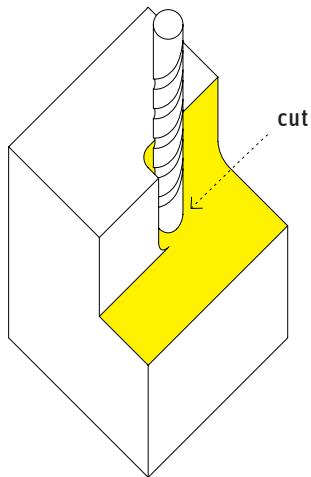

It is possible to create objects with tighter tolerances and better finishes using subtractive manufacturing. When it comes to precision for common functional features such as flat surfaces, drilled and tapped holes, counter sinks, and counter parts, subtractive processes generally achieve results with maximum repeatability and dimensional accuracy. Subtractive fabrication can also apply to 2D objects cut from flat stock.

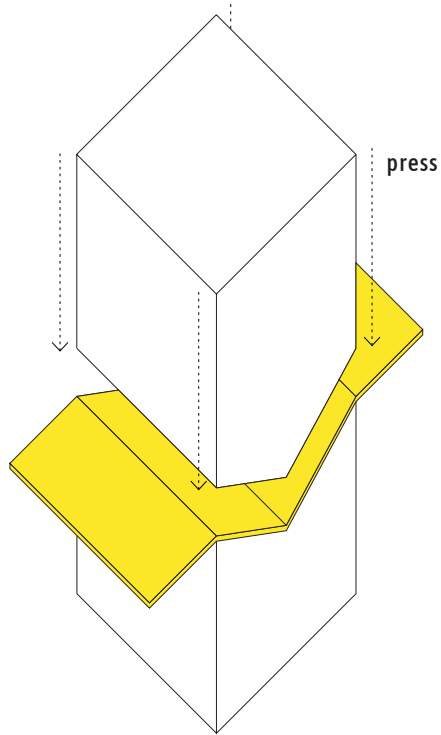

## FORMATIVE FABRICATION

Forming processes make use of stresses like compression, tension, shear, or some combination to cause the plastic deformation of a material into a desired shape. This manufacturing process is typically for plastics and metals.

No material is added or subtracted in this process. The workpiece is only deformed or displaced. Linear materials such as steel tube, pipe, or rod, and sheet materials such as steel plate or thermoplastic can be bent, curved, sliced, embossed, or deformed into shape through the application of external pressure and/or heat. Such transformation requires tools that can bend, fold, or deform using molds, punches, stamping dies, or bending tools. Material consumption is greatest in this process when molds are used.

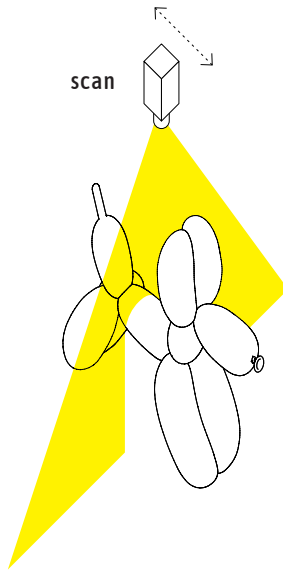

## INPUT

While not a “fabrication” category, inputting information into a digital environment often goes hand-in-hand with digital fabrication. 3D digital scanners, including some smart phones, can be used to map physical objects.

This may be desirable for a variety of reasons. A designer may be interested in scanning a hand-made study model into the computer in order to refine it digitally, study it in a virtual context, or change its scale for future output. Another example might involve the inclusion of a found object into a virtually constructed model.

Inputting technologies are linked to additive, subtractive, and formative digital fabrication through drawings and digital modeling software. 3D scanners enable the designer to make, study, and edit fluidly, across diverse media, both virtual and physical.

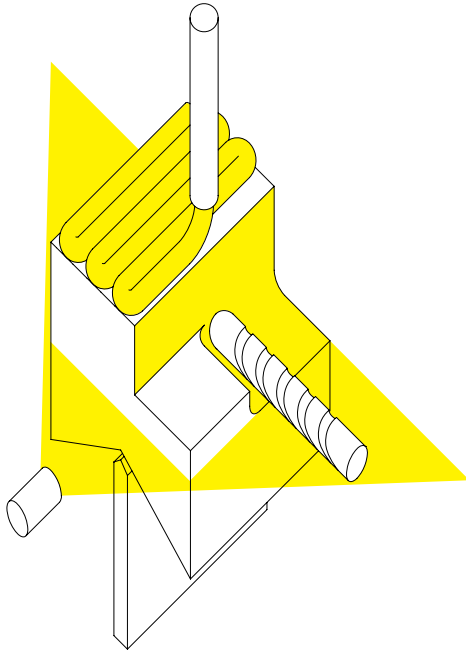

## HYBRIDS

Most tools are designed to do very specific tasks. Some cut curves. Others drill holes. To create material compositions of real complexity, it is typically necessary to apply a variety of tools during a job. This is true in fabrication as well. Combining additive fabrication, subtractive fabrication, formative fabrication, and/or digital input within a single project enables designers to make sophisticated assemblies, tools, and prototypes.



# **ADDITIVE MANUFACTURING**

## ADDITIVE MANUFACTURING

In flat-layer additive fabrication, amorphous material in the form of a liquid, powder, or adhesive film is built-up sequentially in flat layers to form a desired shape. This can be accomplished through a variety of techniques. Five common techniques are as follows: "Selective Surface Curing" applies a laser to set successive layers of liquid resin. "Pattern Lamination" bonds and then cuts successive patterns using layers of adhesive film. "Deposition" involves the placement of successive layers of a fusible material. "Selective Sintering" describes the process of depositing successive layers of a meltable powder and then sintering them using a laser. Sintering is the process of forming a solid mass of material using heat (laser) or pressure without melting it to the point of liquefaction. "Stereolithography" is another 3D printing process where a light-emitting device (laser or DLP) selectively illuminates the transparent bottom of a tank filled with a liquid photo-polymerizing resin. The solidified resin is progressively dragged up by a lifting platform, resulting in a 3D object.

Each approach has advantages and limitations. These include speed of production, cost of the machine, cost of the final build, durability or flexibility of the build (how will the prototyped piece be used and is the material appropriate to that use), aesthetics, and resolution.



## FUSED DEPOSITION MODELING (F.D.M.)

FDM (fused deposition modeling) is an additive build process wherein thermoplastic filament is melted and extruded from a printer head and deposited onto a printing bed. The printer builds three-dimensional objects in layers. Each layer is printed in the X and Y directions (as a horizontal surface). Layers aggregate in the Z direction.

PLASTIC WOOD METAL POLYMERS GLASS CERAMICS

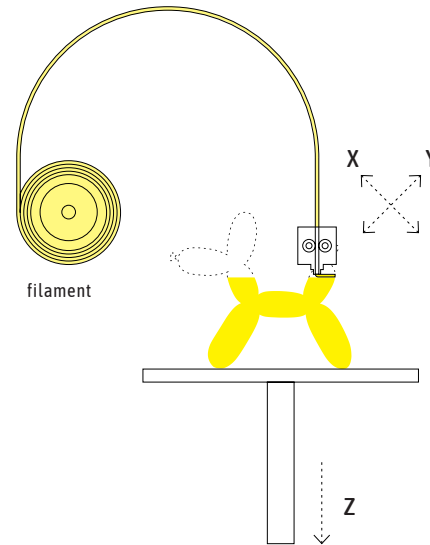



## LAMINATED OBJECT MANUFACTURING

L.O.M (laminated object manufacturing) is a process wherein a sheet material is cut to shape and successively adhered in layers to build a three dimensional object. Layers aggregate in the Z direction.

PLASTIC WOOD METAL POLYMERS GLASS CERAMICS

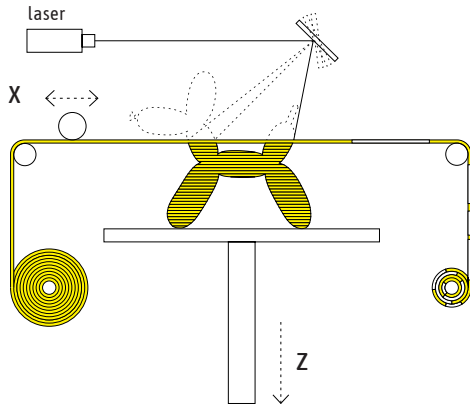

## SELECTIVE LASER MELTING (S.L.M.)

S.L.M. (Selective Laser Melting) is a rapid-prototyping technique that utilizes a high density laser to sinter and fuse metal powder into a desired form. Thin layers of powder are rolled onto the work surface. Then, the laser is applied, selectively melting desired areas of powder to the layer below.

PLASTIC WOOD METAL POLYMERS GLASS CERAMICS

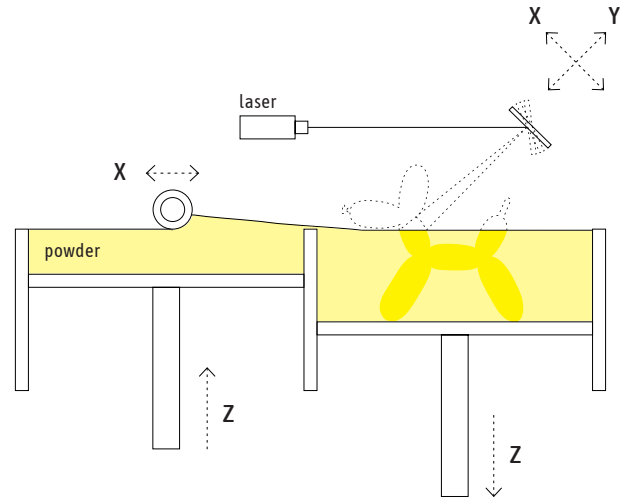



## STEREOLITHOGRAPHY APPARATUS (S.L.A.)

A light-emitting device (laser or DLP) selectively illuminates the transparent surface of a tank filled with a liquid photo-polymerizing resin. The solidified resin is progressively dragged up or down by a lifting platform, resulting in a 3D object.

PLASTIC WOOD METAL POLYMERS GLASS CERAMICS

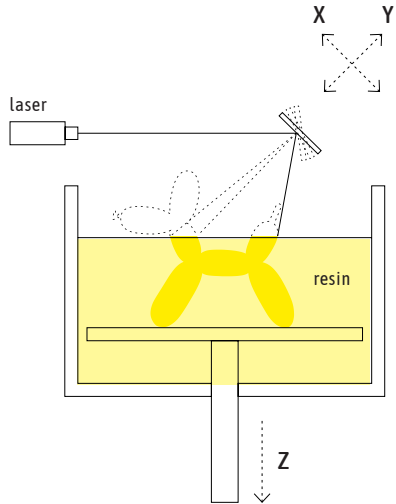

## 3D INK JET

This additive prototyping process uses an ink jet print head that moves across a layer of powder, selectively depositing a binding material. Another thin layer of powder is spread across each completed layer, and the process is repeated until the desired geometry is formed. Excess powder remains in the build bed until the process is complete.

PLASTIC WOOD METAL POLYMERS GLASS CERAMICS

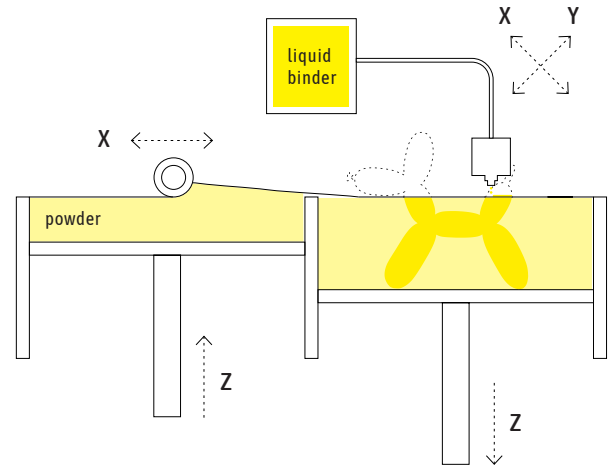

# **SUBTRACTIVE MANUFACTURING**

## SUBTRACTIVE MANUFACTURING

In subtractive digital fabrication a CNC (computer numerically controlled) cutting tool removes material from a solid block of material to reveal a desired shape. This may be done in a variety of ways, including milling, routing, turning (lathe), laser cutting, or water-jet cutting. Many conventional materials can be formed and manipulated using subtractive fabrication techniques. These include wood, plastics, metals, composite materials, fabrics, and paper.

The term “cutters” is used to describe a series of tools used to cut flat material. These include but are not limited to laser cutters, water-jet cutters, plasma cutters, and knife or die-cutters.

Subtractive fabrication can be divided into 3D cutting and 2D cutting. 2D cutting is typically performed by machines that move cutting heads along the X- and Y-axes. It is common for cutting flat stock. Examples include sign cutters, laser cutters, and water-jet cutters.

3D cutting is more complicated, and includes mills that cut with varying degrees of freedom (typically ranging from 3 to 6 degrees of freedom). 3D cutting is akin to carving and is used to produce complex shapes from dimensional stock.



## CNC LATHE

A CNC lathe machine is a computer numerically controlled tool that rotates stock material about an axis of rotation to perform various subtractive operations. These include cutting, sanding, knurling, drilling, deformation, facing, and turning. Tools can be applied to the workpiece to create an object with symmetry about that axis.

---

PLASTIC WOOD METAL POLYMERS GLASS CERAMICS

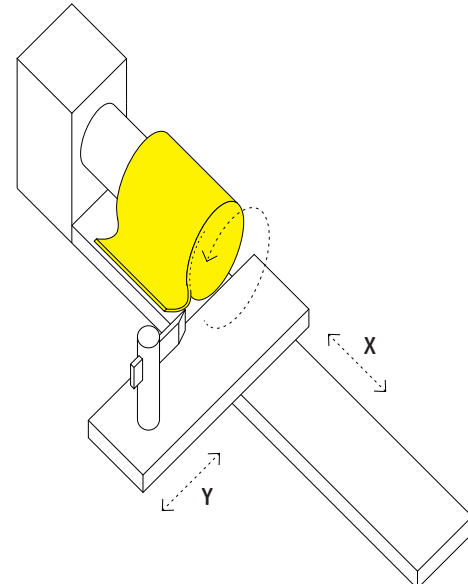



## CNC MILL

A CNC milling machine is a computer controlled machine that is generally used to plane material, drill holes, cut or carve materials. Each of these subtractive tasks do not involve rotating the work piece itself. The Milling machine acts in the X and Y directions while fixed to a moving Z axis arm.

PLASTIC WOOD METAL POLYMERS GLASS CERAMICS

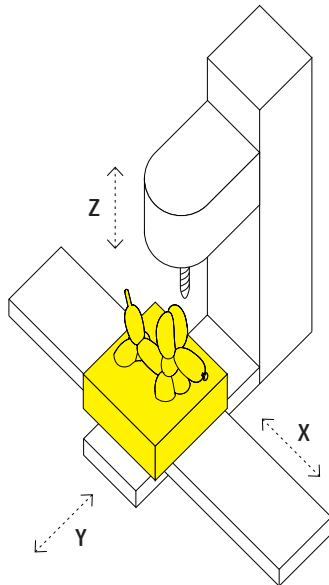

## CNC ROUTER

A CNC router is a computer controlled machine that is capable of cutting a variety of materials. It is conceptually similar to the hand-held router. The CNC router machine translates CAD models into 'G-Code'. This code supplies instructive coordinates to the machine. The router moves across a gantry in the Y-axis and plunges in the Z-axis. The entire gantry moves in the X-axis.

PLASTIC WOOD METAL POLYMERS GLASS CERAMICS

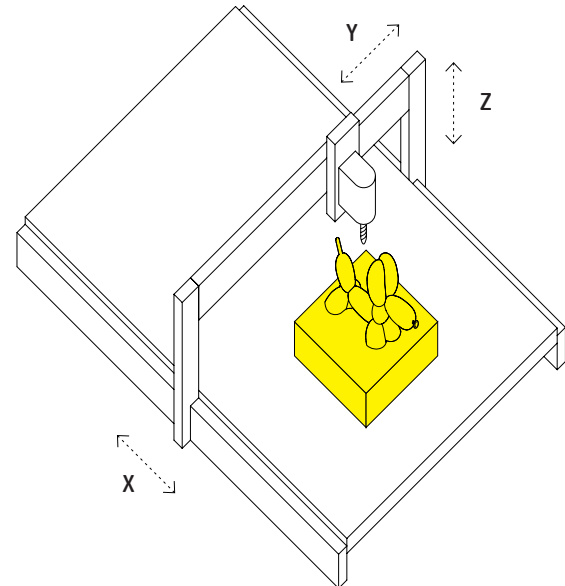



## LASER CUTTER

The laser cutter uses an optically amplified beam of light as a cutting element. That laser can etch, engrave and/or cut non-metallic materials including wood, glass, film, fabric, and plastic. The laser can be focused, and the intensity of light increased or decreased for specific tasks. Cut performance (depth for example) can also be controlled by varying the speed of the cutting head.

PLASTIC WOOD METAL POLYMERS GLASS CERAMICS

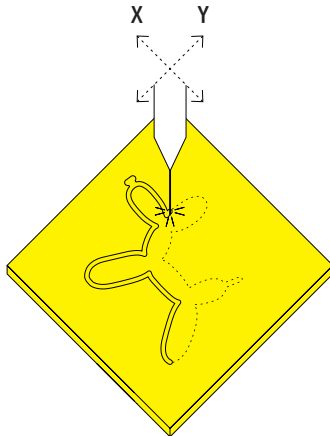

## PLASMA CUTTER

Plasma cutters work by sending an electric arc through a gas that passes through a constricted opening. This elevates the temperature of the gas to the point that it enters a fourth state of matter, plasma. This plasma uses this electrically conductive gas to transfer energy from a power supply to any conductive material, resulting in a clean, fast cut.

PLASTIC WOOD METAL POLYMERS GLASS CERAMICS

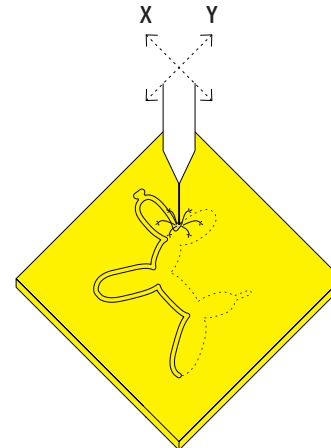





## WATER-JET CUTTER

A water-jet cutter maneuvers a focused high-pressure stream of water to cut a material. Cutting can be done using pure water or water with an abrasive additive material like garnet sand. Garnet sand increases the machines ability to efficiently cut through thicker materials and hard materials such as titanium. Water-jets do not generate heat. This reduces the risk of deformation during cutting.

PLASTIC WOOD METAL POLYMERS GLASS CERAMICS

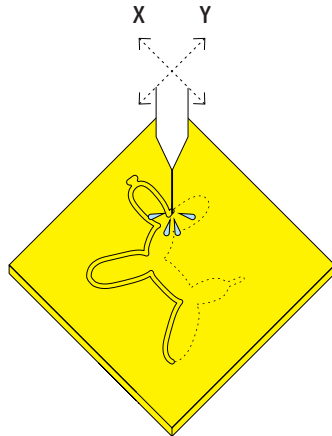

## WIRE EDM

The wire electric discharge machine (EDM) makes cuts using a very thin diameter wire (typically 0.15 to 0.20 mm) charged with extremely high voltage. The taught wire moves between two independently articulated spools as it is drawn through the material being cut. EDM Cutters can cut precise interior corners and can cut on a taper.

PLASTIC WOOD METAL POLYMERS GLASS CERAMICS

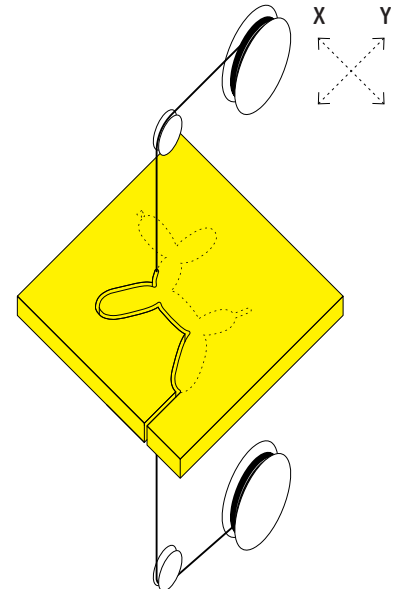

## **FORMATIVE MANUFACTURING**



## FORMING

Forming processes make use of stresses like compression, tension, shear (or some combination) to cause the plastic deformation of a material into a desired shape. This manufacturing process typically makes use of plastics and metals.

Hand-operated presses, brakes, and benders are used to produce many one-off prototypes in fabrication. These typically produce elements with singular standard modification. Sheet materials being formed with more complexity, multi-directional curvatures, or voluminous shapes may require a custom die or mold. The mold can significantly increase the cost of a part. Costs drop when the part is repeated.

## CNC PRESS BRAKE

A CNC Press Brake is a computer controlled machine used to perform bending operations on sheet material (usually sheet metal). It can be configured to do a sequence of bends at a variety of angles.

PLASTIC WOOD METAL POLYMERS GLASS CERAMICS

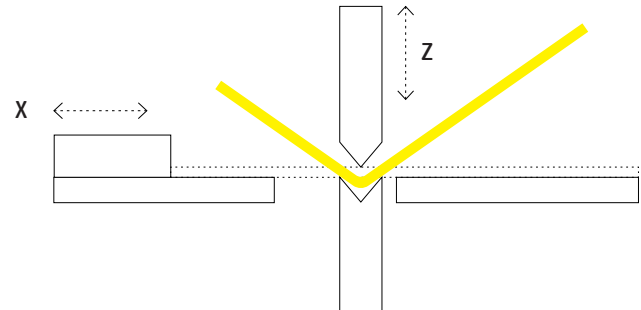



## CNC PUNCH PRESS

A CNC Punch Press is a computer controlled machine that uses pre-formed dies to punch specific shapes out of sheet material (usually sheet metal). These machines can generate single cuts or cuts organized in a designer determined pattern.

PLASTIC WOOD METAL POLYMERS GLASS CERAMICS

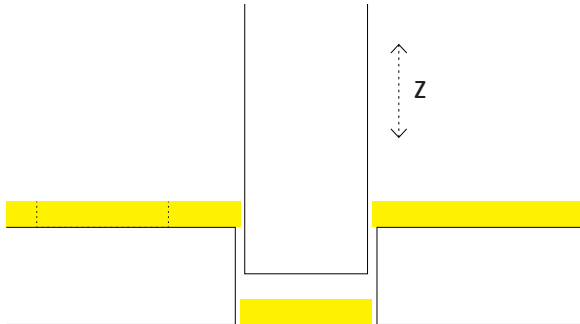

## CNC ROLLER

A CNC Roller is a computer controlled machine that can create specific curved bends in sheet and stock material. It is comprised of 3-4 rollers. Rollers can be repositions. The diameter and position of the rollers determine the smallest radii possible in the bend.

PLASTIC WOOD METAL POLYMERS GLASS CERAMICS

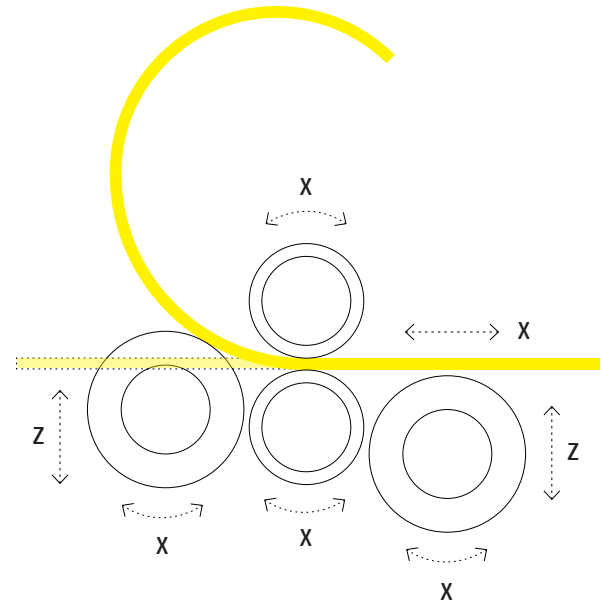



## CNC TUBE BENDER

A CNC Tube Bender is a computer controlled machine that can create a series of complex curved bends in pipe material. This tool is capable of bending pipe in a variety of radii and directions.

---

PLASTIC WOOD METAL POLYMERS GLASS CERAMICS

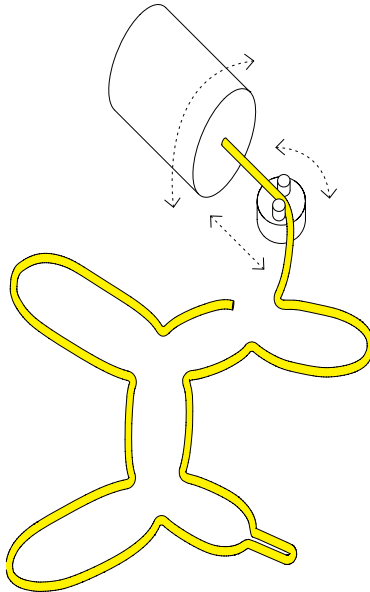

## VACUUM FORMER

Vacuum forming is a method of thermoforming. Sheet material (typically plastic) is placed in frame within the vacuum former and heated until malleable. Once the plastic has a desirable amount of pliability, it is pulled over the mold. Once in position, a vacuum is applied, removing air from between the material and form. This draws the material tightly around the mold, making a copy.

---

PLASTIC WOOD METAL POLYMERS GLASS CERAMICS

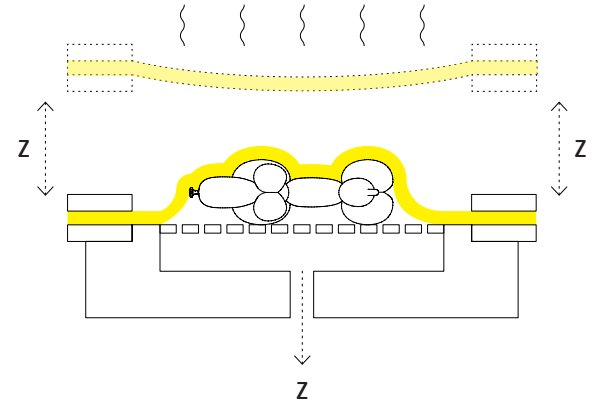



## SINGLE POINT FORMING (S.P.F.)

S.P.F. (single point forming) is a process where sheet material is incrementally dented into a desired three dimensional shape, usually by a round-tipped tool. This is the CNC equivalent to hammer formed metal.

PLASTIC WOOD METAL POLYMERS GLASS CERAMICS

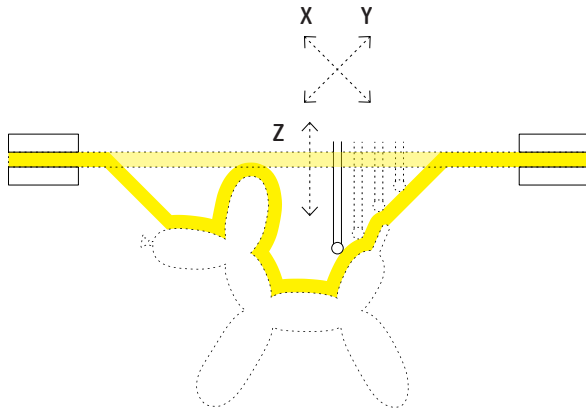

## ROTMOLDING

Rotomolding, or rotational molding, is a process where raw material (usually in powder form) is injected into a heated, hollow mold. The mold slowly rotates on one or more axes to allow the softened material to disperse and adhere to the interior walls of the mold. The constant rotation helps to maintain an even material thickness and also prevents sagging and other deformation.

PLASTIC WOOD METAL POLYMERS GLASS CERAMICS

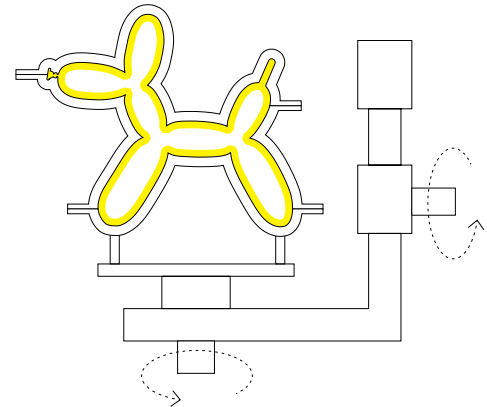



## INJECTION MOLDING

Injection molding is a process in which molten material is injected into an interior mold. When the material cools and hardens it takes the formal configuration of the cavity. Rotomolds can make hollow objects. Injection molds make solid objects.

---

PLASTIC WOOD METAL POLYMERS GLASS CERAMICS

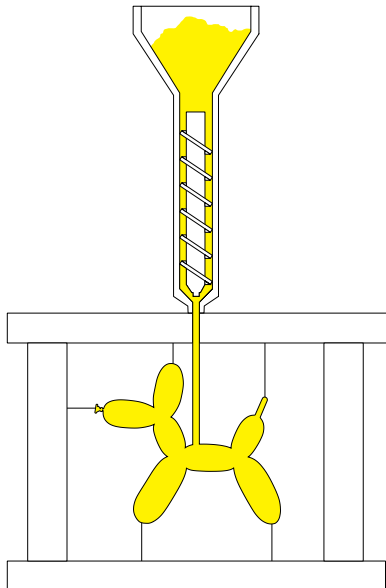

INPUT

## INPUT

Initially digital fabrication was used to generate designs in a virtual environment and output them via fabrication tools into the physical world. As all of these tools become more sophisticated and interconnected, the need and desire to insert physical objects into the virtual world has increased. A variety of input tools and methods are available for accomplishing this task. Several are listed in this document.



## LIDAR

“Light Detection and Ranging” or LIDAR is a method of measuring distance with pulsed laser light. The pulsing laser is aimed at an object or surface and the reflected light is measured with a sensor. A model is rendered by calculating the distance the light has traveled. It is commonly used for surveying to make high resolution maps.

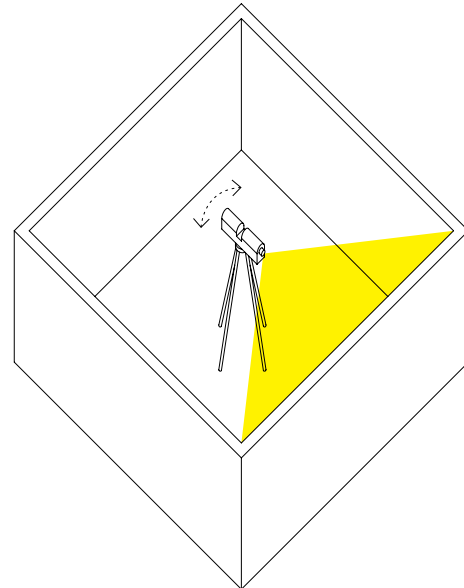





## MOTION CAPTURE

Motion Capture is used to record the movement of people or objects. Capturing the visual appearance of an object is not as important as capturing its movement through space. Motion capture is used in a wide range of fields including the military, entertainment and health industries, and in robotics.

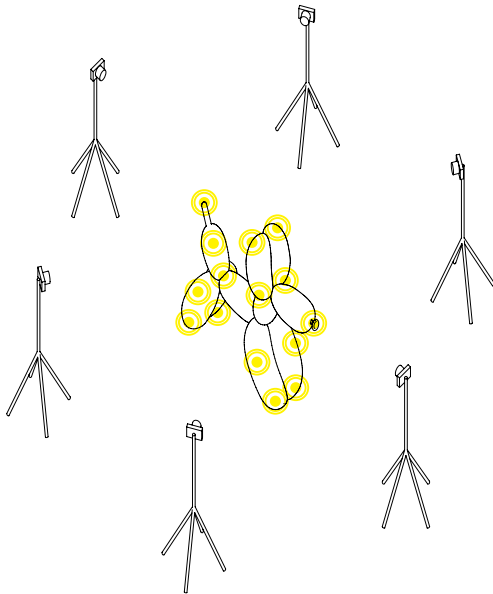

## PHOTOGRAMMETRY

Photogrammetry is used to generate measurements from photographs. This technique can generate maps, drawings, or 3D models. The two main types of photogrammetry are Aerial Photogrammetry (a view from the sky) and Terrestrial Photogrammetry (a view from the ground). A series of images are cross referenced to calculate changes in surface and form.

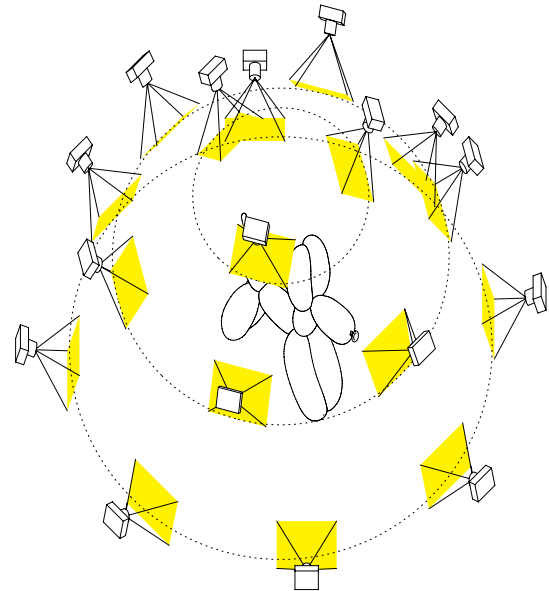



## PROFILE SCANNER

Profile scanners (or laser scanners), are used to detect, measure, and analyze the profiles on an object's surface.

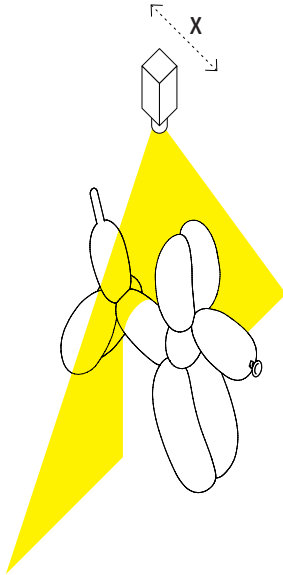

## STRUCTURED-LIGHT

Structured-Light scanning starts with the projecting a light patterns on to an object. The pattern deforms as it meets surfaces, and the deformations provide a means of measuring depth and surface information.

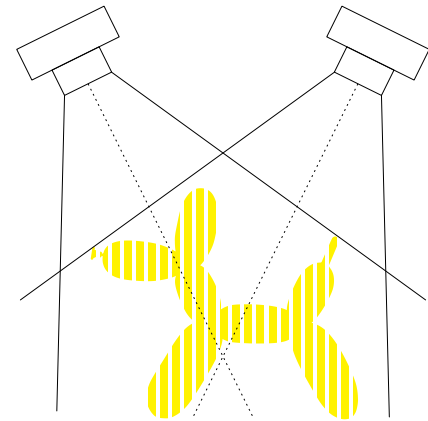



## 3D BODY SCAN

3D Body Scanning techniques can capture the human form as a point-cloud to reveal exact proportional and ergonomic measurements. Technologies include but are not limited to structured-light scanning, 3D depth sensing, and stereoscopic vision.

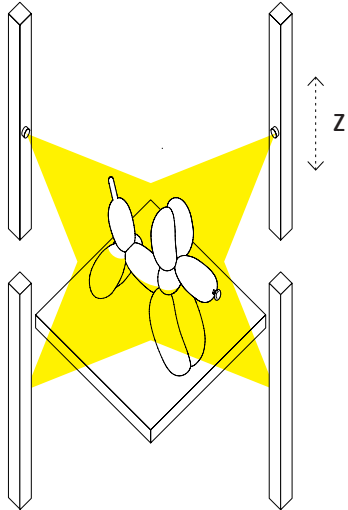

## ACKNOWLEDGEMENTS

This project would not have been possible without the help and support of the Teaching Learning Enhancement Fund Grant program. SALA offers its sincere thanks and gratitude to the TLEF program, its organizers, and the students of UBC who fund the program. Thank you for your support in our project.

Many people contributed to this document, including Blair Satterfield, Graham Entwistle, Sam Hart, Lisa Kusaka, Derek Mays, Alana Paven, Alex Preiss, Sébastien Roy, Kara Verbeek, and Amy Wu.



UNIVERSITY OF BRITISH COLUMBIA 2018 ©  
SCHOOL OF ARCHITECTURE + LANDSCAPE ARCHITECTURE

